



PDHonline Course C277 (4 PDH)

Dredging Methods and Equipment

Instructor: John Huang, Ph.D., PE and John Poullain, PE

2020

PDH Online | PDH Center

5272 Meadow Estates Drive
Fairfax, VA 22030-6658
Phone: 703-988-0088
www.PDHonline.com

An Approved Continuing Education Provider

CHAPTER 2
DESIGN CONSIDERATIONS

2-1. General. A dredging and dredged material disposal operation requires consideration of both short- and long-term management objectives. The primary short-term objective of a dredging project is to construct or maintain channels for existing navigation needs but not necessarily to authorized project dimensions. This should be accomplished using the most technically satisfactory, environmentally compatible, and economically feasible dredging and dredged material disposal procedures. Long-term objectives concern the management and operation of disposal areas to ensure their long-term use. This chapter outlines the design consideration usually needed to meet the objectives of a dredging project.

2-2. Preliminary Data Collection. In order to gather the data required for a dredging and dredged material disposal project, it is necessary to do the following:

- a. Analyze dredging location and quantities to be dredged, considering future needs.
- b. Determine the physical and chemical characteristics of the sediments.
- c. Evaluate potential disposal alternatives.
- d. Identify pertinent social, environmental, and institutional factors.
- e. Evaluate dredge plant requirements.

2-3. Dredging Locations and Quantities.

a. Dredging locations and the quantities of material to be dredged are two of the most important considerations in planning dredging projects. Since disposal of dredged material is usually the major dredging problem, it is essential that long-term projections be made for disposal requirements of each project. Records should be kept of quantities dredged and maintenance interval(s) to forecast future dredging and disposal requirements.

b. Hydrographic surveys are the principal dredged contract management tool of the Corps. Hydrographic surveys should be made prior to dredging to determine existing depths within the project area and after dredging to determine the depths that were attained as a result of the dredging operation. Each district should have the capability, either in-house or by contract, to make accurate, timely, and repeatable hydrographic surveys. To ensure accuracy, quantity calculations must be made from survey data gathered in a timely manner using proper equipment and based upon precisely established horizontal and vertical controls. Direct tide level readings must be made at the site of the work to eliminate gross errors in quantity calculations. Quantity measurement methods must be fully consistent

between work performed by contract and work performed by hired labor.

2-4. Physical Properties of Sediments. In planning any dredging operation which constitutes a specialized problem in earthmoving or excavation, it is essential that field measurements and computations be made to determine the location, characteristics, and quantities of material to be removed. The characteristics of the dredged material determine dredge plant and, to some extent, disposal requirements. Refer to Chapter 4 for specific characterization tests required for evaluation and design of disposal alternatives for dredged material.

a. Sampling. Sediment samples should be taken of the material above the depth to which removal will be credited. This should be done concurrent with the pre-dredge survey. For maintenance dredging of a recurring nature, samples will be taken before each dredging until the characteristics of the sediments are well known. For subsequent dredging, a small number of samples will be taken to identify and changes in sediment characteristics. Normally the sediment sampling depth will be the authorized project depth plus an allowable tolerance (usually 2 ft) to compensate for the inherent inaccuracies of the dredging process. The number of sediment samples taken should be sufficient to obtain accurate information regarding the characteristics of the material to be dredged. Samples in soft materials can be obtained by push tube or grab samplers.

(1) Tube sampling.

(a) A tube sampler is an open-ended tube that is thrust vertically into the sediment deposit to the depth desired. The sampler is withdrawn from the deposit with the sample retained within the tube. Differences among tube samplers relate to tube size, tube wall thickness, type of penetrating nose, head design including valve, and type of driving force. Tube samplers (also called harpoon samplers) are available with adjustable weights in the range of from 17 to 77 lb and with fixed weights in excess of 90 lb. The amount of weight required depends upon deposit texture and required depth of penetration.

(b) The split barrel sample spoon (also known as split-spoon sampler) is capable of penetrating hard sediments, provided sufficient force is applied to the driving rods. The sampler is thrust into the deposit by the hammering force exerted on rods connected to the head. During retrieval, the sample is retained within the barrel by a flap. The nose and head are separated from the barrel in order to transfer the sample to a container. Refer to EM 1110-2-1907 for more information on soil sampling.

(2) Grab sampling. A grab sampler consists of a scoop or bucket container that bites into the soft sediment deposit and encloses the sample. Grab samplers are used primarily to sample surface materials, with depth of penetration being 12 in. or less. Grab samplers are easy and inexpensive to obtain and may be sufficient to characterize sediment for routine maintenance dredging. Grab sampling may indicate relatively homogeneous sediment composition, segregated pockets or coarse- and fine-grained sediment, and/or mixtures. If segregated pockets are present, samples should be taken at

a sufficient number of locations in the channel to adequately define spatial variations in the sediment character and quantities of each material.

(3) New work. Samples taken by conventional boring techniques are normally required for new work dredging. Samples should be taken from within the major zones of spatial variation in sediment type or along the proposed channel center line at constant spacing to define stratification within the material to be dredged and to obtain representative samples. Borings are required for new projects and should be advanced below the depth of anticipated dredging. The relative density of sands can be determined by driving a split-spoon sampler and recording the number of blows required to penetrate each foot of sand. Refer to EM 1110-2-1907 for information on conventional soil sampling methods and standard split-spoon penetration tests. Information on the soil above and below the authorized new work depth is needed to properly design the channel slopes. It is essential to obtain the characteristics of the material to be dredged to preclude determination of unsuitable dredge plant, unrealistic production and cost estimates, etc. Pertinent information regarding sediment samplers is summarized in table 2-1.

b. Laboratory Testing. Laboratory tests are required to provide data for determining the proper dredge plant, evaluating and designing disposal alternatives, designing channel slopes and retention dikes, and estimating long-term storage capacity for confined disposal areas. The tests discussed below are to be used to characterize the material to be dredged so that a proper dredge plant can be selected. Specific tests for evaluation and design of disposal alternatives are discussed in Chapter 4. The required laboratory tests are essentially standard tests and generally follow procedures found in EM 1110-2-1906. The extent of the testing program is project-dependent: fewer tests are required when dealing with a relatively homogeneous material and/or when data are available from previous tests and experience, as is frequently the case in maintenance dredging; for new work projects and unusual maintenance dredging projects where considerable variation in sediment properties is apparent from samples, more extensive laboratory testing programs are required. Laboratory tests should always be performed on representative sediment samples. Tests required on fine-grained sediments (those of which more than half pass through a No. 40 sieve) include natural water content, plasticity analyses (Atterberg limits), and specific gravity. The coarse-grained sediments (those of which more than half are retained on a No. 40 sieve) require only grain size analyses and in situ density determinations. These tests are described below.

(1) Natural water content test. Natural water content refers to the in situ water content of the sediment. It is used to determine the in situ void ratio and in situ density of fine-grained sediments. Water content determinations should be made on representative samples from borings and grab samples of fine-grained sediment obtained during field investigation. Fine-grained sediments do not drain rapidly; thus, representative samples taken from borings and grab samples are considered to represent in situ water contents. Detailed test procedures for determining the water content are found in Appendix I of EM 1110-2-1906.

Table 2-1. Summary of Sediment Sampling Equipment

Sampler	Weight	Remarks
Peterson	39-93 lb	Samples 144-in. ² area to a depth of up to 12 in., depending on sediment texture
Shipek	150 lb	Samples 64-in. ² area to a depth of approximately 4 in.
Ekman	9 lb	Suitable only for very soft sediments
Ponar	45-60 lb	Samples 81-in. ² area to a depth of less than 12 in. Ineffective in hard clay
Drag Bucket	Varies	Skims an irregular slice of sediment surface. Available in assorted sizes and shapes
Phleger Tube (gravity corer)	Variable : 17-77 lb; fixed in excess of 90 lb	Shallow core samples may be obtained by self-weight penetration and/or pushing from boat. Depth of penetration dependent on weight and sediment texture
Conventional Soil Samplers	Refer to EM 1110-2-1907	Conventional soil samplers may be employed using barge- or boat-mounted drilling equipment. Core samples attainable to full depth of dredging

25 Mar 83

(2) Plasticity analyses. Plasticity analyses (Atterberg limits) should be performed on the separated fine-grained fraction (passing the No. 40 sieve) of sediment samples. A detailed explanation of the tests required to evaluate the plasticity of sediments is presented in Appendix III of EM 1110-2-1906. Samples should be classified according to the Unified Soil Classification System (USCS) (item 12).

(3) Specific gravity test. Values for the specific gravities of solids in fine-grained sediments are required for determining void ratios and in situ densities. Procedures for conducting the specific gravity test are given in Appendix IV of EM 1110-2-1906.

(4) Grain size analyses. Grain size analyses are required only on the coarse-grained fraction of samples. Grain size analyses should follow the procedures contained in Appendix V of EM 1110-2-1906.

c. In situ density. In situ density is used to evaluate dredgability to sediments and aid in equipment selection, to estimate production rates, and to estimate volume required for storage in confined disposal areas. In situ density can be estimated from field investigations of sediments or from laboratory test data using geotechnical engineering formulas. Refer to Appendix II of EM 1110-2-1906 for guidance in estimating in situ density from laboratory tests. For sand sediments, relative density has a decisive influence on the selection of equipment for dredging. The relative density of sands can be estimated from standard split-spoon penetration tests (para 2-4a). Table 2-2 presents estimates of relative density of sands based on standard penetration tests. Where no field tests are performed on coarse-grained materials (i.e. sand, gravel, etc.,) the material in its densest state based on laboratory tests will be considered comparable to its in situ condition.

Table 2-2. Relative Density of Sands According to Results of Standard Penetration Tests

<u>No. of Blows/ft</u>	<u>Relative Density</u>
0-4	Very loose
4-10	Loose
10-30	Medium
30-50	Dense
Over 50	Very dense

2-5. Selection of Dredging Equipment. Most Corps dredging is performed by private industry under contract, and the specifications should not be written such that competitive bidding is restricted. However, in certain situations limitations may be placed on the equipment to be used to minimize the environmental impact of the dredging and disposal operation. In cases where available upland containment areas are small, the size of the dredge should be restricted to minimize stress on the containment area dikes and to provide adequate retention time for sedimentation to minimize

excessive suspended solids in the weir effluent. Environmental protection is adequate justification for carefully controlling the selection and use of dredging equipment. The dredging of contaminated sediments requires careful assessment of the dredging operation. The information presented in Chapters 3 and 4 will provide guidance for proper equipment selection based on the materials to be dredged, dredging environment, contamination level of sediments, transport and disposal requirements, and production requirements.

2-6. Disposal Alternatives. The major considerations in selecting disposal alternatives are the environmental impact and the economics of the disposal operation. Much of the recent knowledge concerning dredged material disposal was gained as a result of the Dredged Material Research Program (DMRP) conducted by the U.S. Army Engineer Waterways Experiment Station (WES) and reported in WES Technical Reports. The major objectives of the DMRP were to provide definitive information on the environmental impact of dredging and dredged material disposal operations and to develop new or improved dredged material disposal practices. The research was conducted on a national basis, excluding no major types of dredging activity or region or environmental setting. It produced methods for evaluating the physical, chemical, and biological impacts of a variety of disposal alternatives in water, on land, or in wetland areas, as well as tested, viable, cost-effective methods and guidelines for reducing the impacts of conventional disposal alternatives. Summary reports produced under this program are listed in para 1-3, and a detailed discussion of disposal alternatives is presented in Chapter 4. Two fundamental conclusions were drawn from the results of the DMRP concerning disposal of dredged material: (1) no single disposal alternative can be presumed most suitable for a region, a type of dredged material, or a group of projects before it has been tested, and (2) environmental considerations make necessary long-range regional planning for lasting, effective solutions to disposal concerns. There is no inherent effect or characteristic of a disposal alternative that can rule it out of consideration from an environmental standpoint before specific on-site evaluation. This holds true for open-water disposal, confined upland disposal, habitat development, or any other alternative. Case-by-Case project evaluations are time-consuming and expensive and may seriously complicate advanced planning and funding requests. Nevertheless, from a technical point of view, situations can be envisioned where tens of millions of dollars may have been or could be spent for disposal alternatives that contribute to adverse environmental effects rather than reduce them. Also, easily obtained beneficial impacts should not be overlooked. No category of disposal alternative is without environmental risk or offers the soundest environmental protection or reflects the best management practice; therefore, all disposal alternatives should be fully investigated during the planning process and treated on an equal basis until a final decision can be made based on all available facts. It is hypothesized that all alternatives could be considered to dispose of even the most highly contaminated dredged material if a plan could be devised for management that was adequate and legally acceptable under domestic regulations and international treaty.

2-7. Long-Range Studies. Dredging and disposal activities cannot be

designed independently for each of several projects in a given area. While each project may require different specific solutions, the interrelationships among them must be determined. Thought must also be given to changing particular dredging techniques and disposal alternatives as conditions change. Long-range regional dredging and disposal management plans not only offer greater opportunities for environmental protection and effective use of dredging equipment at reduced project cost, but they also meet with greater public acceptance once they are agreed upon. Long-range plans must reflect sound engineering design, consider and minimize any adverse environmental impacts, and be operationally implementable.

CHAPTER 3
DREDGING EQUIPMENT AND TECHNIQUES

3-1. Purpose. This chapter includes a description of the dredging equipment and techniques used in dredging activities in the United States and presents advantages and limitations for each type of dredge. Guidance is provided for selection of the best dredging equipment and techniques for a proposed dredging project to aid in planning and design.

3-2. Factors Determining Equipment Selection.

a. The types of equipment used, by both the Corps and private industry, and the average annual amount of dredging associated with each type are shown in Figure 3-1. The dredging methods employed by the Corps vary considerably throughout the United States. Principal types of dredges include hydraulic pipeline types (cutterhead, dustpan, plain suction, and sidecaster), hopper dredges, and clamshell dredge. The category of "other" dredges in Figure 3-1 includes dipper, ladder, and special purpose dredges. However, there are basically only three mechanisms by which dredging is actually accomplished:

(1) Suction dredging. Removal of loose materials by dustpans, hoppers, hydraulic pipeline plain suction, and sidecasters, usually for maintenance dredging projects.

(2) Mechanical dredging. Removal of loose or hard, compacted materials by clamshell, dipper, or ladder dredges, either for maintenance or new work projects.

(3) A combination of suction and mechanical dredging. Removal of loose or hard, compacted materials by cutterheads, either for maintenance or new work projects.

b. Selection of dredging equipment and method used to perform the dredging will depend on the following factors:

- (1) Physical characteristics of material to be dredged.
- (2) Quantities of material to be dredged.
- (3) Dredging depth.
- (4) Distance to disposal area.
- (5) Physical environment of and between the dredging and disposal areas.
- (6) Contamination level of sediments.
- (7) Method of disposal.

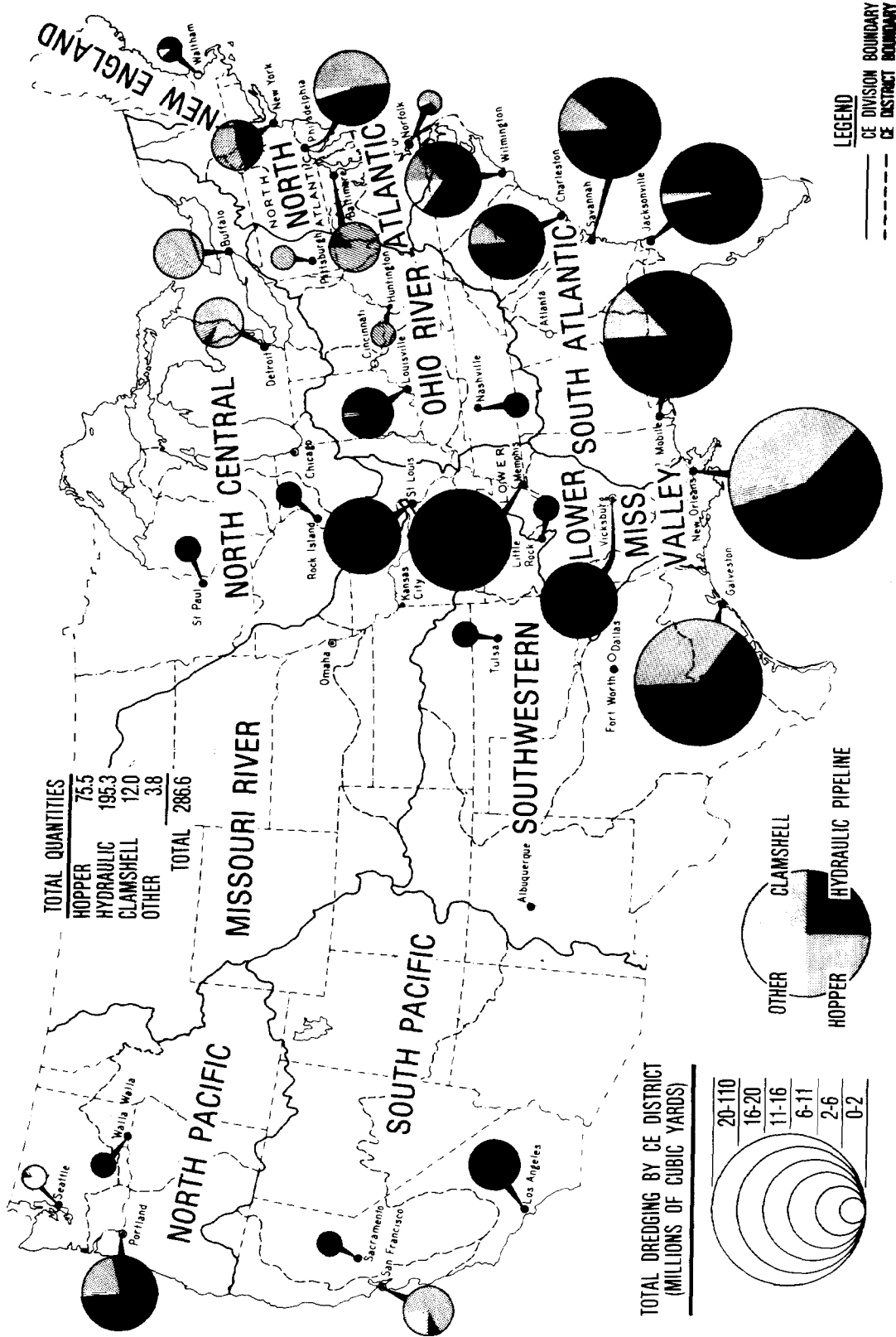

Figure 3-1. Types of dredges used and estimated quantities to be dredged by each District (FY 81).

(8) Production required.

(9) Type of dredges available.

3-3. Hopper Dredges.

a. General. Hopper dredges are self-propelled seagoing ships of from 180 to 550 ft in length, with the molded hulls and lines of ocean vessels (fig. 3-2). They are equipped with propulsion machinery, sediment containers (hoppers), dredge pumps, and other special equipment required to perform their essential function of removing material from a channel bottom or ocean bed. Hopper dredges have propulsion power adequate for required free-running speed and dredging against strong currents and excellent maneuverability for safe and effective work in rough, open seas. Dredged material is raised by dredge pumps through dragarms connected to drags in contact with the channel bottom and discharged into hoppers built in the vessel. Hopper dredges are classified according to hopper capacity: large-class dredges have hopper capacities of 6000 cu yd or greater, medium-class hopper dredges have hopper capacities of 2000 to 6000 cu yd, and small-class hopper dredges have hopper capacities of from less than 2000 to 500 cu yd. During dredging operations, hopper dredges travel at a ground speed of from 2 to 3 mph and can dredge in depths from about 10 to over 80 ft. They are equipped with twin propellers and twin rudders to provide the required maneuverability. Table 3-1 gives available specifications for all vessels in the Corps hopper dredge fleet.

b. Description of Operation.

(1) General. Operation of a seagoing hopper dredge involves greater effort than that required for an ordinary ocean cargo vessel, because not only the needs of navigation of a self-propelled vessel but also the needs associated with its dredging purposes must be satisfied. Dredging is accomplished by progressive traverses over the area to be dredged. Hopper dredges are equipped with large centrifugal pumps similar to those employed by other hydraulic dredges. Suction pipes (dragarms) are hinged on each side of the vessel with the intake (drag) extending downward toward the stern of the vessel. The drag is moved along the channel bottom as the vessel moves forward at speeds up to 3 mph. The dredged material is sucked up the pipe and deposited and stored in the hoppers of the vessel. Once fully loaded, hopper dredges move to the disposal site to unload before resuming dredging. Unloading is accomplished either by opening doors in the bottoms of the hoppers and allowing the dredged material to sink to the open-water disposal site or by pumping the dredged material to upland disposal sites. Because of the limitations on open-water disposal, most hopper dredges have direct pumpout capability for disposal in upland confined sites. Before there were environmental restrictions, hopper dredges were operated with the primary objective of obtaining the maximum economic load; i.e., removing the maximum quantity of material from the channel prism in the shortest pumping time during a day's operation.

(2) Hopper dredging is accomplished by three methods: (a) pumping past overflow, (b) agitation dredging, and (c) pumping to overflow. The

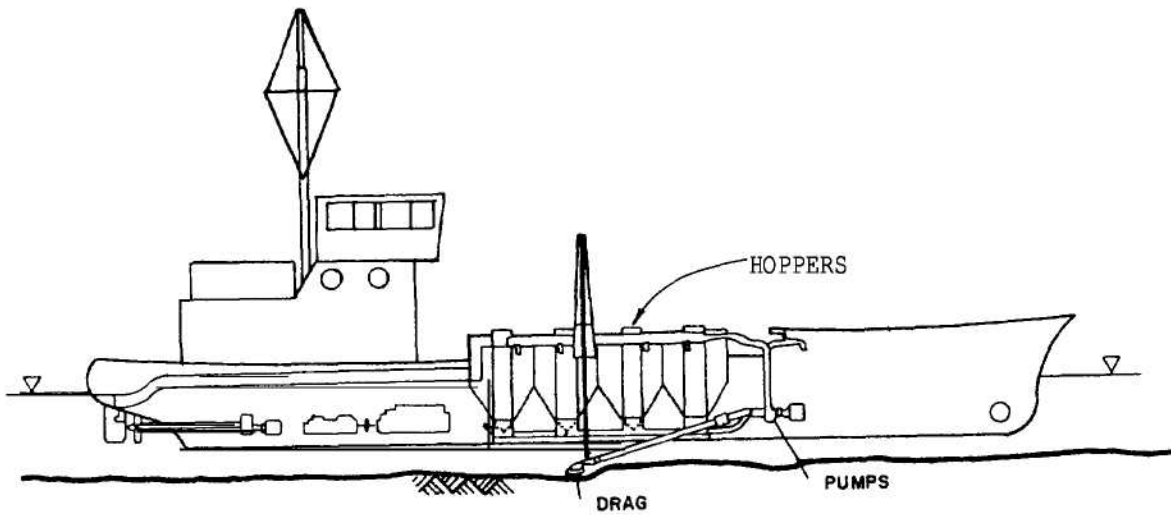

Figure 3-2. Self-propelled seagoing hopper dredge.

Table 3-1. Pertinent Characteristics of Corps of Engineers Hopper Dredges.

Name	Hopper Capacity cu yd	Dredged Pumps Number	Pumps Size Drive	Light Loaded Speed mph	Hull		Draft Loaded	Dredging Depth Max	Vertical Clearance Required	Regional Location	Special Capability
					Material Length	Beam Depth					
BIDDLE	3060	2	28" Electric	17.3	Steel	60'0"	62'	83'	West Coast	None	
ESSAYONS	6000	-- ^a	--	15.4	Steel	351'9"	24'9"	80'	--	Gulf Coast	Direct pumpout
					Steel	350'	27'				
HAINS	855	1	20" Electric	14.1	Steel	40'4"	36'	69'		Great Lakes	Direct pumpout Sidecasting
					Steel	215'10"	13'0"				
WHEELER	8400	--	--	16.1	Steel	78'	80'	--	Gulf Coast	Direct pumpout	
YAQUINA	825	--	--	11.5	Steel	409'	29'5"	45'	--	West Coast	Direct pumpout
					Steel	200'	12'				
MACFARLAND	3140	2	34" Electric	15.4	Steel	72'0"	55'	90'		East Coast	Direct pumpout Sidecasting
					Steel	319'8"	22'0"				
MARKHAM	2780	2	23" Electric	16.7	Steel	62'0"	45'	90'		Great Lakes	Direct pumpout
					Steel	339'6"	19'4"				
PACIFIC	500	1	18" Electric	11.5	Steel	38'0"	45'	70'		West Coast	None
					Steel	180'3"	12'0"				

^aData unavailable.

use of these methods is controlled to varying degrees by environmental legislation and the water quality certification permits required by the various states in which dredging is being accomplished. The environmental effects of these methods must be assessed on a project-by-project basis. If the material being dredged is clean sand, the percentage of solids in the overflow will be small and economic loading may be achieved by pumping past overflow. When contaminated sediments are to be dredged and adverse environmental effects have been identified, pumping past overflow is not recommended. In such cases, other types of dredges may be more suitable for removing the contaminated sediments from the channel prism. If hopper dredges are not allowed to pump past overflow in sediments that have good settling properties, the cost of dredging increases. The settling properties of silt and clay sediments may be such that only a minimal load increase would be achieved by pumping past overflow. Economic loading, i.e. the pumping time required for maximum production of the hopper dredge, should be determined for each project. These determinations, along with environmental considerations, should be used to establish the operation procedures for the hopper dredge.

(3) Agitation dredging. Agitation dredging is a process which intentionally discharges overboard large quantities of fine-grained dredged material by pumping past overflow, under the assumption that a major portion of the sediments passing through the weir overflow will be transported and permanently deposited outside the channel prism by tidal, river, or littoral currents. Agitation dredging should be used only when the sediments dredged have poor settling properties, when there are currents in the surrounding water to carry the sediments from the channel prism, and when the risk to environmental resources is low. Favorable conditions may exist at a particular project only at certain times of the day, such as at ebb tides, or only at such periods when the streamflow is high. To use agitation dredging effectively requires extensive studies of the project conditions and definitive environmental assessments of the effects. Agitation dredging should not be performed while operating in slack water or when prevailing currents permit redeposit of substantial quantities of the dredged material in the project area or in any other area where future excavation may be required. Refer to para 3-12 for more information on this topic.

(4) Refer to ER 1125-2-312 for instructions for hopper dredge operations.

c. Application. Hopper dredges are used mainly for maintenance dredging in exposed harbors and shipping channels where traffic and operating conditions rule out the use of stationary dredges. The materials excavated by hopper dredges cover a wide range of types, but the hopper dredge is most effective in the removal of material which forms shoals after the initial dredging is completed. While specifically designed drags are available for use in raking and breaking up hard materials, hopper dredges are most efficient in excavating loose, unconsolidated materials. At times, hopper dredges must operate under hazardous conditions caused by fog, rough seas, and heavy traffic encountered in congested harbors.

d. Advantages. Because of the hopper dredge's design and method of

operation, the self-propelled seagoing hopper dredge has the following advantages over other types of dredges for many types of projects:

- (1) It is the only type of dredge that can work effectively, safely, and economically in rough, open water.
- (2) It can move quickly and economically to the dredging project under its own power.
- (3) Its operation does not interfere with or obstruct traffic.
- (4) Its method of operation produces usable channel improvement almost as soon as work begins. A hopper dredge usually traverses the entire length of the problem shoal, excavating a shallow cut during each passage and increasing channel depth as work progresses.
- (5) The hopper dredge may be the most economical type of dredge to use where disposal areas are not available within economic pumping distances of the hydraulic pipeline dredge.

e. Limitations. The hopper dredge is a seagoing self-propelled vessel designed for specific dredging projects. The following limitations are associated with this dredge:

- (1) Its deep draft precludes use in shallow waters, including barge channels.
- (2) It cannot dredge continuously. The normal operation involves loading, transporting material to the dump site, unloading, and returning to the dredging site.
- (3) The hopper dredge excavates with less precision than other types of dredges.
- (4) Its economic load is reduced when dredging contaminated sediments since pumping past overflow is generally prohibited under these conditions and low-density material must be transported to and pumped into upland disposal areas.
- (5) It has difficulty dredging side banks of hardpacked sand.
- (6) The hopper dredge cannot dredge effectively around piers and other structures.
- (7) Consolidated clay material cannot be economically dredged with the hopper dredge.

3-4. Cutterhead Dredges.

a. General. The hydraulic pipeline cutterhead suction dredge is the most commonly used dredging vessel and is generally the most efficient and versatile (fig. 3-3). It performs the major portion of the dredging

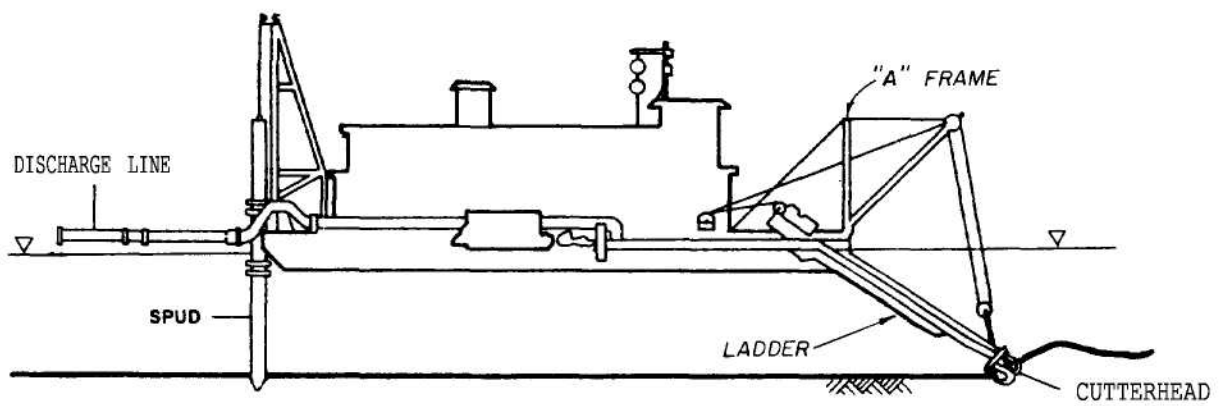
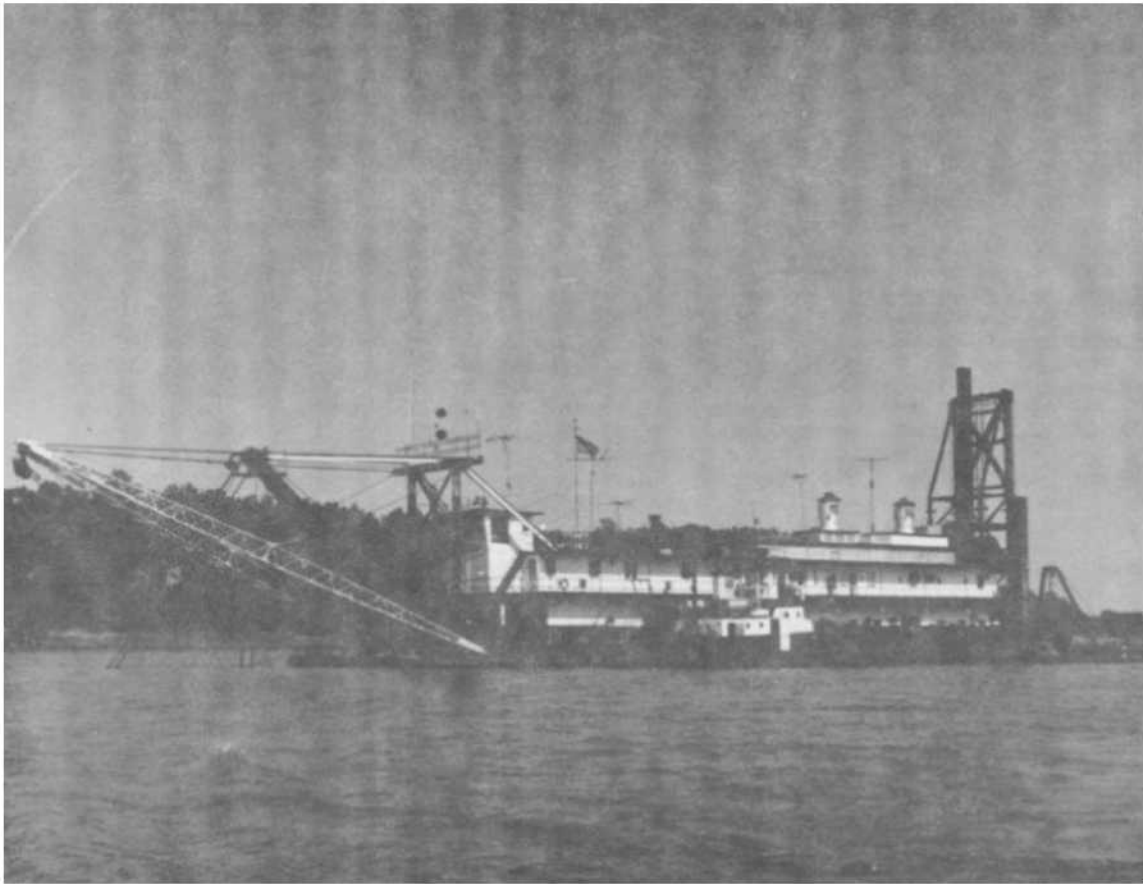

Figure 3-3. Hydraulic pipeline cutterhead dredge.

25 Mar 83

workload in the United States. Because it is equipped with a rotating cutter apparatus surrounding the intake end of the suction pipe, it can efficiently dig and pump all types of alluvial materials and compacted deposits, such as clay and hardpan. This dredge has the capability of pumping dredged material long distances to upland disposal areas. Slurries of 10 to 20 percent solids (by dry weight) are typical, depending upon the material being dredged, dredging depth, horsepower of dredge pumps, and pumping distance to disposal area. If no other data are available, a pipeline discharge concentration of 13 percent by dry weight (145 ppt) should be used for design purposes. Pipeline discharge velocity, under routine working conditions, ranges from 15-20 ft/sec. Table 3-2 presents theoretical pipeline discharge rates as functions of pipeline discharge velocities for dredges ranging in sizes from 8 to 30 in.

Table 3-2. Suction Dredge Pipeline Discharge Rates,^a
cu ft/sec

Discharge Velocity ft/sec	Discharge Pipe Diameter			
	a in.	18 in.	24 in.	30 in.
10	3.5	17.7	31.4	49.1
15	5.2	26.5	47.1	73.6
20	7.0	35.3	62.8	98.1
25	8.7	44.2	78.5	122.7

^aDischarge rate = pipeline area x discharge velocity.

Production rate is defined as the number of cubic yards of in situ sediments dredged during a given period and is usually expressed in cu yd/hr. Production rates of dredges vary according to the factors listed above and other operational factors that are not necessarily consistent between dredges of the same size and type. For example, a 16-in. dredge should produce between 240 and 875 cu yd of dredged material per hour, and a 24-in. dredge should produce between 515 and 1615 cu yd per hour. The range for typical cutterhead production as a function of dredge size is shown in figure 3-4. This figure illustrates the wide range of production for dredges of the same size. The designer can refer to figure 3-5, which shows the relationships among solids output, dredge size, and pipeline length for various dredging depths, as a preliminary selection guide for the size of dredge required for a given project. This is only a rough guide, and accurate calculations based not only on the type of material to be dredged but on the power available and other considerations should be completed before a final engineering recommendation can be made. The designer should refer to the data available from ENG Form 4267, "Report of Operations-- Pipeline, Dipper, or Bucket Dredges," for use in estimating production rates, effective working time, etc. These data on past dredging projects are available in the Construction-Operation Divisions of the Districts. Specifications and dimensions for several cutterhead dredges ranging in pipe diameter from 6 to 30 in. are presented in table 3-3.

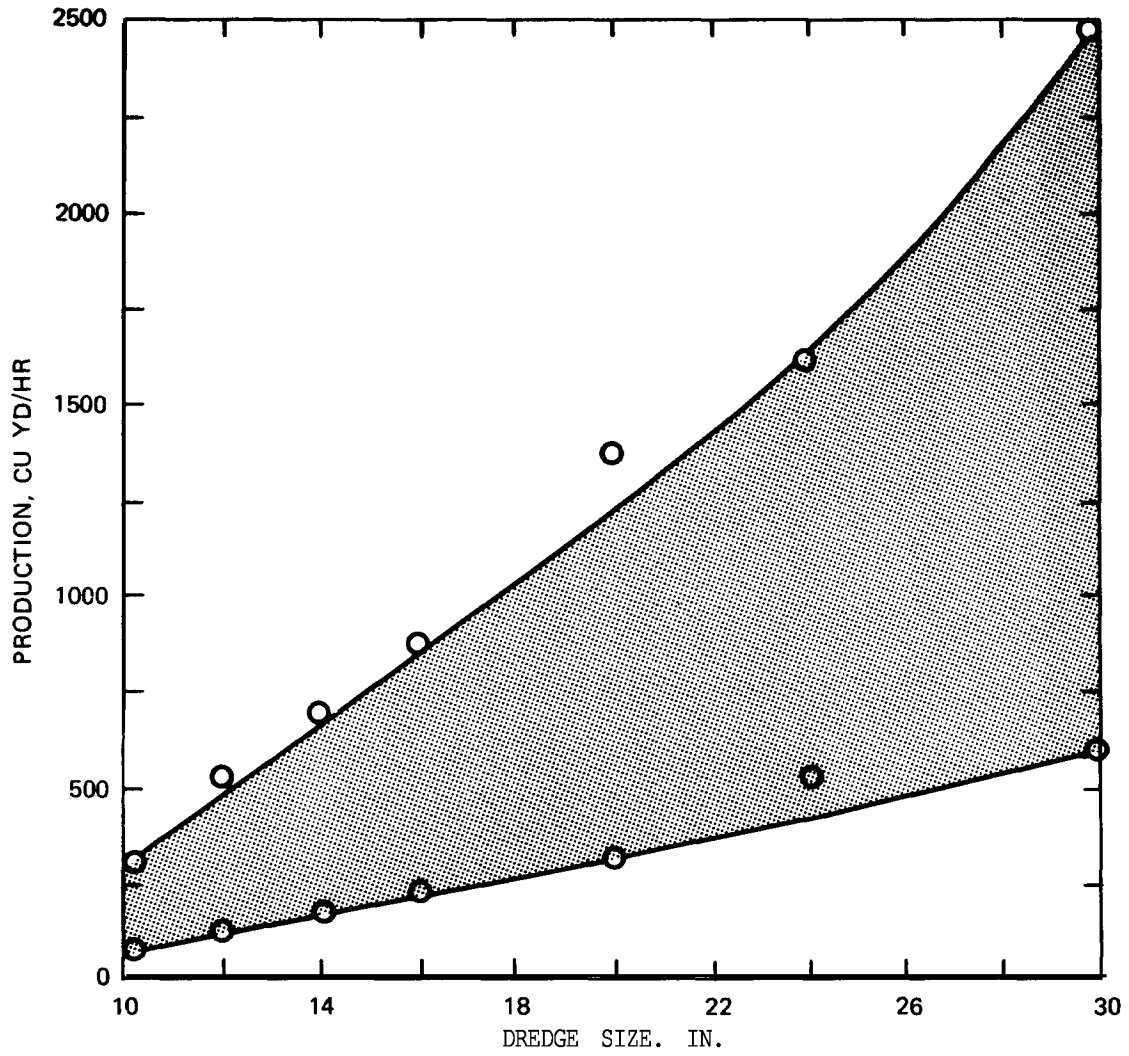

Figure 3-4. Typical cutterhead dredge production according to dredge size.

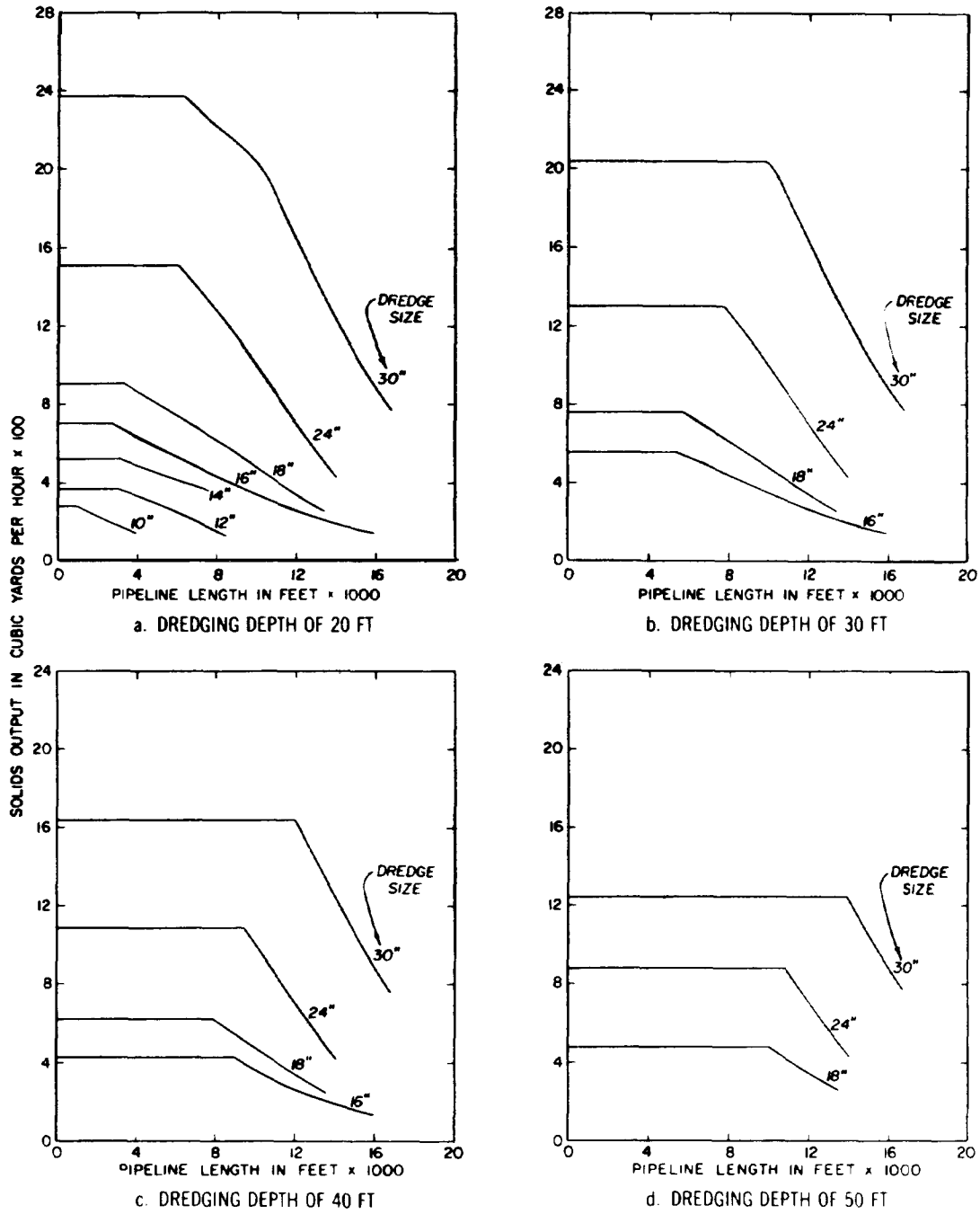

Figure 3-5. Relationships among solids output, dredge size, and pipeline length for various dredging depths- (WES TR DS-78-10)

Table 3-3. Specifications for Typical Dustpan and Cutterhead Dredges.

Dredge Type	Pipeline Diameter in.	Weight tons	Length ft	Width ft	Height ft	Draft in.	Freeboard in.	Dredge Pumps			Production Rate cu_yd/hr	Dredging Depth ft	Depth of Single Pass Excavation in.	
								No.	hp	Size Drive				
Dustpan	32	--	244	50	60	60	48	1	2100	38	Steam	3500	60	60
Cutterhead	6	18.5	44	11	20	34	14	1	175	8	Diesel	25-95	12	18
Cutterhead	8	18.5	44	11	20	35	13	1	175	8	Diesel	45-105	12	18
Cutterhead	10	72.5	90	17	33	43	17	1	335	12	Diesel	60-300	25	18
Cutterhead	12	73.5	90	20	33	42	18	1	520	14	Diesel	120-540	25	18
Cutterhead	14	87	95	20	33	43	17	1	520	16	Diesel	160-700	25	21
Cutterhead	16	166	130	28	55	55	17	1	1125	18	Diesel	240-875	40	21
Cutterhead	20	316	180	32	70	54	42	1	1700	24	Diesel	310-1365	50	24
Cutterhead	24	326	185	32	70	56	40	1	2250	24	Diesel	515-1615	50	30
Cutterhead	30	350	225	36	67	60	36	1	3600	30	Diesel	575-2500	50	36

b. Description of Operation. The cutterhead dredge is generally equipped with two stern spuds used to hold the dredge in working position and to advance the dredge into the cut or excavating area. During operation, the cutterhead dredge swings from side to side alternately using the port and starboard spuds as a pivot, as shown in figure 3-6. Cables attached to anchors on each side of the dredge control lateral movement. Forward movement is achieved by lowering the starboard spud after the port swing is made and then raising the port spud. The dredge is then swung back to the starboard side of the cut centerline. The port spud is lowered and the starboard spud lifted to advance the dredge. The excavated material may be disposed of in open water or in confined disposal areas located upland or in the water. In the case of open-water disposal, only a floating discharge pipeline, made up of sections of pipe mounted on pontoons and held in place by anchors, is required. Additional sections of shore pipeline are required when upland disposal is used. In addition, the excavated materials may be placed in hopper barges for disposal in open water or in confined areas that are remote from the dredging area. In cutterhead dredging, the pipeline transport distances usually range up to about 3 miles. For commercial land reclamation or fill operations, transport distances are generally longer, with pipeline lengths reaching as far as 15 miles, for which the use of multiple booster pumps is necessary.

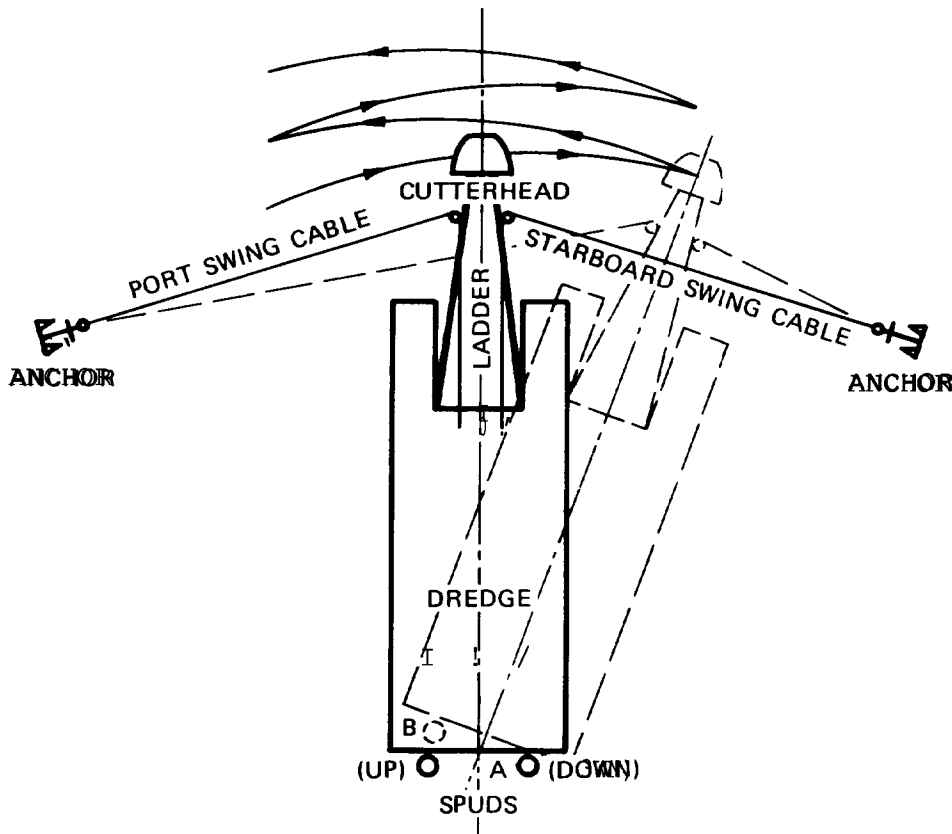

Figure 3-6. Operation of a cutterhead dredge (viewed from above).

c. Application. Although the cutterhead dredge was developed to loosen up densely packed deposits and eventually cut through soft rock, it can excavate a wide range of materials including clay, silt, sand, and gravel. The cutterhead, however, is not needed in maintenance dredging of most materials consisting of clay, silt, and fine sand because in these materials, rotation of the cutterhead produces a turbidity cloud and increases the potential for adverse environmental impacts. Common practice is to use the cutterhead whether it is needed or not. When the cutterhead is removed, cutterhead dredges become in effect plain suction dredges. The cutterhead dredge is suitable for maintaining harbors, canals, and outlet channels where wave heights are not excessive. A cutterhead dredge designed to operate in calm water will not operate offshore in waves over 2-3 ft in height; the cutterhead will be forced into the sediment by wave action creating excessive shock loads on the ladder. However, a cutterhead dredge designed to operate offshore can operate in waves up to about 6 ft.

d. Advantages. The cutterhead dredge is the most widely used dredge in the United States because of the following advantages:

(1) Cutterhead dredges are used on new work and maintenance projects and are capable of excavating most types of material and pumping it through pipelines for long distances to upland disposal sites.

(2) The cutterhead operates on an almost continuous dredging cycle, resulting in maximum economy and efficiency.

(3) The larger and more powerful machines are able to dredge rocklike formations such as coral and the softer types of basalt and limestone without blasting.

e. Limitations. The limitations on cutterhead dredges are as follows:

(1) The cutterhead dredges available in the United States have limited capability for working in open-water areas without endangering personnel and equipment. The dredging ladder on which the cutterhead and suction pipe are mounted is rigidly attached to the dredge; this causes operational problems in areas with high waves.

(2) The conventional cutterhead dredges are not self-propelled. They require the mobilization of large towboats in order to move between dredging locations.

(3) The cutterhead dredge has problems removing medium and coarse sand in maintaining open channels in rivers with rapid currents. It is difficult to hold the dredge in position when working upstream against the river currents since the working spud often slips due to scouring effects. When the dredge works downstream, the material that is loosened by the cutterhead is not pulled into the suction intake of the cutterhead. This causes a sandroll, or berm, of sandy material to form ahead of the dredge.

(4) The pipeline from the cutterhead dredge can cause navigation problems in small, busy waterways and harbors.

3-5. Dustpan Dredge.

a. General. The dustpan dredge is a hydraulic suction dredge that uses a widely flared dredging head along which are mounted pressure water jets (fig. 3-7). The jets loosen and agitate the sediments which are then captured in the dustpan head as the dredge itself is winched forward into the excavation. This type of dredge was developed by the Corps of Engineers to maintain navigation channels in uncontrolled rivers with bedloads consisting primarily of sand and gravel. The first dustpan dredge was developed to maintain navigation on the Mississippi River during low river stages. A dredge was needed that could operate in shallow water and be large enough to excavate the navigation channel in a reasonably short time. The dustpan dredge operates with a low-head, high-capacity centrifugal pump since the material has to be raised only a few feet above the water surface and pumped a short distance. The dredged material is normally discharged into open water adjacent to the navigation channel through a pipeline usually only 800 to 1000 ft long.

b. Description of Operation. The dustpan dredge maintains navigation channels by making a series of parallel cuts through the shoal areas until the authorized widths and depths are achieved. Typical operation procedures for the dustpan dredge are as follows:

(1) The dredge moves to a point about 500 ft upstream of the upper limit of the dredging area and the hauling anchors are set. Two anchors are used, as shown in Figure 3-8. The hauling winch cables attached to the anchors are crossed to provide better maneuverability and control of the vessel while operating in the channel prism.

(2) The dredge is then moved downstream to the desired location. The suction head is lowered to the required depth, dredge pump and water jet pumps are turned on, and the dredging commences. The dredge is moved forward by the hauling cables. The rate of movement depends on the materials being dredged, depth of dredging, currents, and wind. In shallow cuts, the advance may be as rapid as 800 ft/hr.

(3) When the upstream end of the cut is reached, the suction head is raised and the dredge is moved back downstream to make a parallel cut. This operation is repeated until the desired dredging widths and depths are achieved.

(4) The suction head may have to be lowered or raised if obstacles such as boulders, logs, or tree stumps are encountered. Experience with dustpan dredges indicates that the best results are obtained when the height of the cut face does not exceed 6 ft in depth.

(5) The dredge is moved outside the channel to let waterborne traffic pass through the area simply by raising the suction head and slacking off on one of the hauling winch cables. The propelling engines can be used to assist in maneuvering the dredge clear of the channel. The vessel is held in position by lowering the suction head or by lowering a spud.

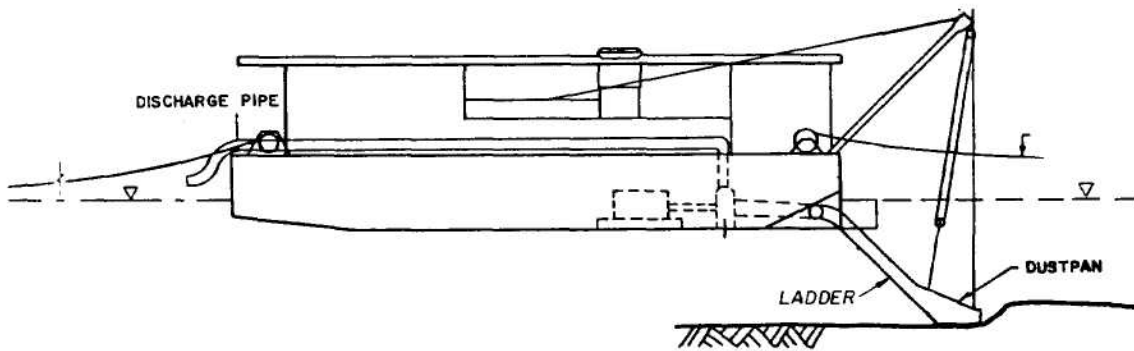
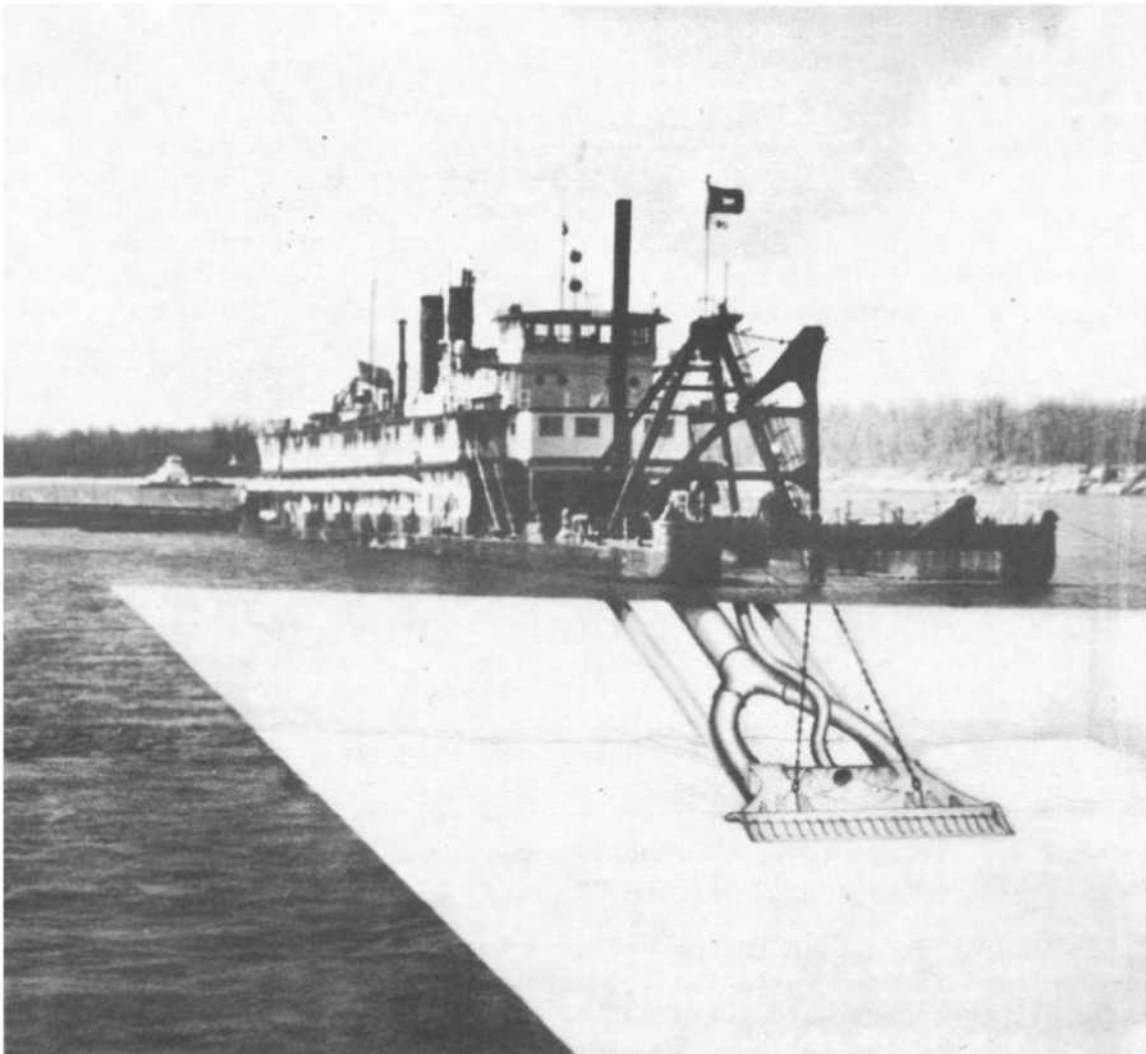

Figure 3-7. Dustpan dredge.

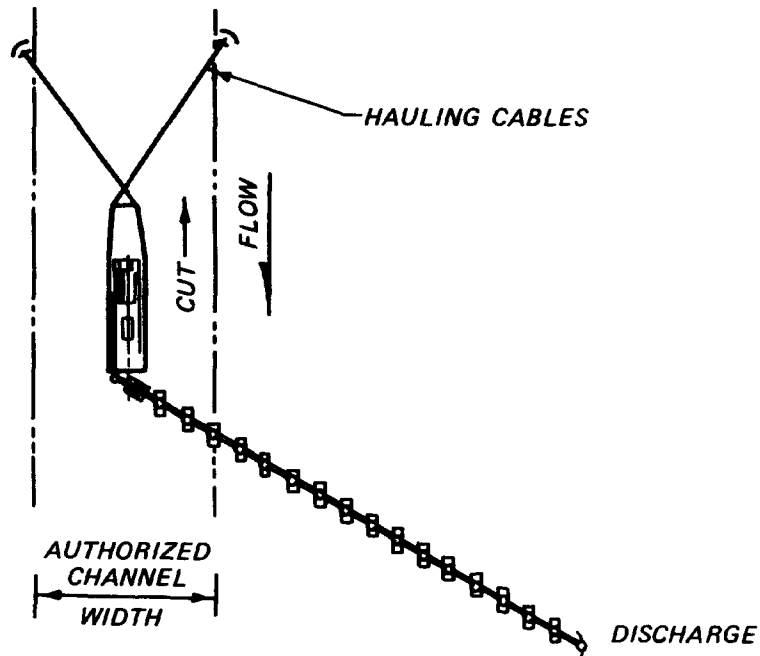

Figure 3-8. Operation of dustpan dredge (viewed from above).

c. Application. The pipeline system and the rigid ladder used with the dustpan dredge make it effective only in rivers or sheltered waters; it cannot be used in estuaries or bays where significant wave action occurs. Because it has no cutterhead to loosen hard, compact materials, the dustpan dredge is mostly suited for high-volume, loose-material dredging. Dustpan dredges are used to maintain the navigation channel of the uncontrolled open reaches of the Mississippi, Missouri, and Ohio Rivers. Dustpan dredging is principally a low-stage season operation. River channels are surveyed before the end of the high-stage season to determine the location and depths at the river crossings and sandbar formations, and dustpan dredging operations are planned accordingly. The existing fleet of Corps dustpan dredges is described briefly in table 3-4.

Table 3-4. Corps Dustpan Dredges.

Name	District Location	Discharge Diameter, in.	Age, years
Mitchell	Kansas City	34	47
Burgess	Memphis	32	47
Ockerson	Memphis	32	49
Potter	St. Louis	32	49
Jadwin	Vicksburg	32	47

These dredges are high-volume dredges capable of excavating a navigation channel through river sediment in a short time. During FY 71, the dredge Jadwin excavated over 6,200,000 cu yd, with an average production rate of approximately 3600 cu yd/hr. Detailed operations data for all the dustpan

dredges are reported on ENG Form 4267, "Report of Operations--Pipeline, Dipper, or Bucket Dredges." Refer to table 3-3 for specifications for a typical dustpan dredge.

d. Advantages. The dustpan dredge is self-propelled, which enables it to move rapidly over long distances to work at locations where emergencies occur. The attendant plant and pipeline are designed for quick assembly so that work can be started a few hours after arrival at the work site. The dustpan dredge can move rapidly out of the channel to allow traffic to pass and can resume work immediately. The high production rate and design of the dustpan dredge make it possible to rapidly remove sandbar formations and deposits from river crossings so that navigation channels can be maintained with a minimum of interruption to waterborne traffic.

e. Limitations. The dustpan dredge was designed for a specific purpose, and for this reason there are certain limitations to its use in other dredging environments. It can dredge only loose materials such as sands and gravels and only in rivers or sheltered waters where little wave action may be expected. The dustpan dredge is not particularly well suited for transporting dredged material long distances to upland disposal sites; pumping distances are limited to about 1000 ft without the use of booster pumps.

3-6. Sidecasting Dredges.

a. General. The sidecasting type of dredge (fig. 3-9) is a shallow-draft seagoing vessel, especially designed to remove material from the bar channels of small coastal inlets. The hull design is similar to that of a hopper dredge; however, sidecasting dredges do not usually have hopper bins. Instead of collecting the material in hoppers onboard the vessel, the sidecasting dredge pumps the dredged material directly overboard through an elevated discharge boom; thus, its shallow draft is unchanged as it constructs or maintains a channel. The discharge pipeline is suspended over the side of the hull by structural means and may be supported by either a crane or a truss-and-counterweight design. The dredging operations are controlled by steering the vessel on predetermined ranges through the project alignment. The vessel is self-sustaining and can perform work in remote locations with a minimum of delay and service requirements. The projects to which the sidecasters are assigned for the most part are at unstabilized, small inlets which serve the fishing and small-boat industries. Dangerous and unpredictable conditions prevail in these shallow inlets making it difficult for conventional plant to operate except under rare ideal circumstances.

b. Description of Operation. The sidecasting dredge picks up the bottom material through two dragarms and pumps it through a discharge pipe supported by a discharge boom. During the dredging process, the vessel travels along the entire length of the shoaled area casting material away from and beyond the channel prism. Dredged material may be carried away from the channel section by littoral and tidal currents. The construction of a deepened section through the inlet usually results in some natural scouring and deepening of the channel section, since currents moving through the prism tend to concentrate the scouring action in a smaller active zone. A typical sequence of events in a sidecasting operation is as follows:

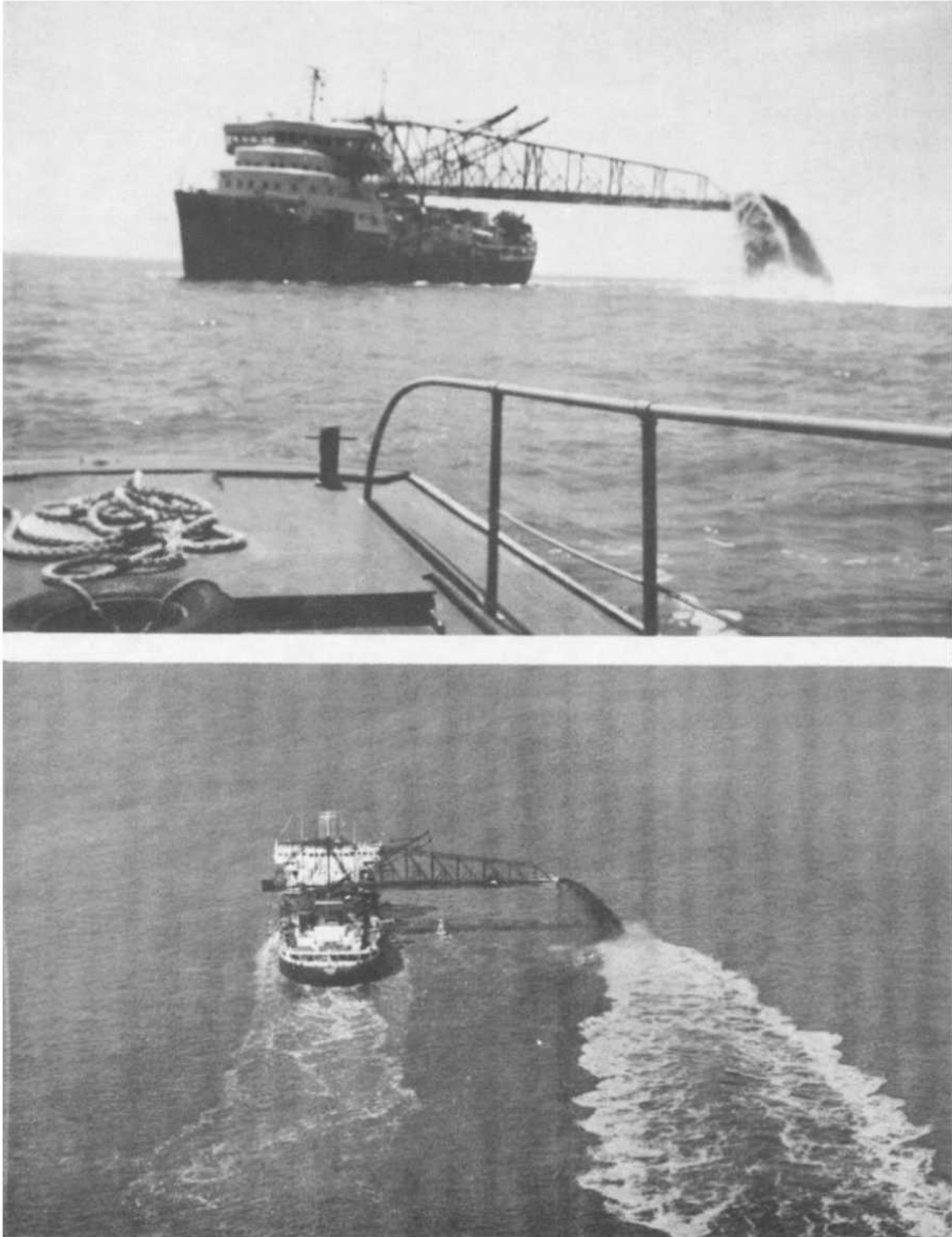

Figure 3-9. Sidecasting dredge.

- (1) The dredge moves to the work site.
- (2) The dragarms are lowered to the desired depth.
- (3) The pumps are started to take the material from the channel bottom and pump it through the discharge boom as the dredge moves along a designated line in the channel prism.
- (4) If adequate depths are not available across the bar during low tide levels, dredging must be started during higher tide levels. Under these conditions, the cuts are confined to a narrow channel width to quickly attain the flotation depth necessary for dredging to be continued during the low tidal periods.
- (5) The dredge continues to move back and forth across the bar until the channel dimensions are restored.
- (6) The discharge can be placed on either side of the dredge by rotating the discharge boom from one side of the hull to the other.

c. Application. The Corps of Engineers developed the shallow-draft sidecasting dredge for use in places too shallow for hopper dredges and too rough for pipeline dredges. The types of materials that can be excavated with the sidecasting dredge are the same as for the hopper dredges (para 3-3c).

d. Advantages. The sidecasting type of dredge, being self-propelled, can rapidly move from one project location to another on short notice and can immediately go to work once at the site. Therefore, a sidecasting dredge can maintain a number of projects located great distances from each other along the coastline.

e. Limitations. The sidecasting dredge needs flotation depths before it can begin to work because it dredges while moving over the shoaled area. Occasionally, a sidecaster will need to alter its schedule to work during higher tide levels periods only, due to insufficient depths in the shoaled area. Most areas on the seacoast experience a tidal fluctuation sufficient to allow even the shallowest shoaled inlets to be reconstructed by a sidecasting type of dredge. A shallow-draft sidecasting dredge cannot move large volumes of material compared to a hopper dredge, and some of the material removed can return to the channel prism due to the effects of tidal and littoral currents. The sidecasting dredge has only open-water disposal capability; therefore, it cannot be used for dredging contaminated sediments.

3-7. Dipper Dredges.

a. General. The dipper dredge is basically a barge-mounted power shovel. It is equipped with a power-driven ladder structure and operated from a barge-type hull. A schematic drawing and photograph of the dipper dredge are shown in figure 3-10. A bucket is firmly attached to the ladder structure and is forcibly thrust into the material to be removed. To

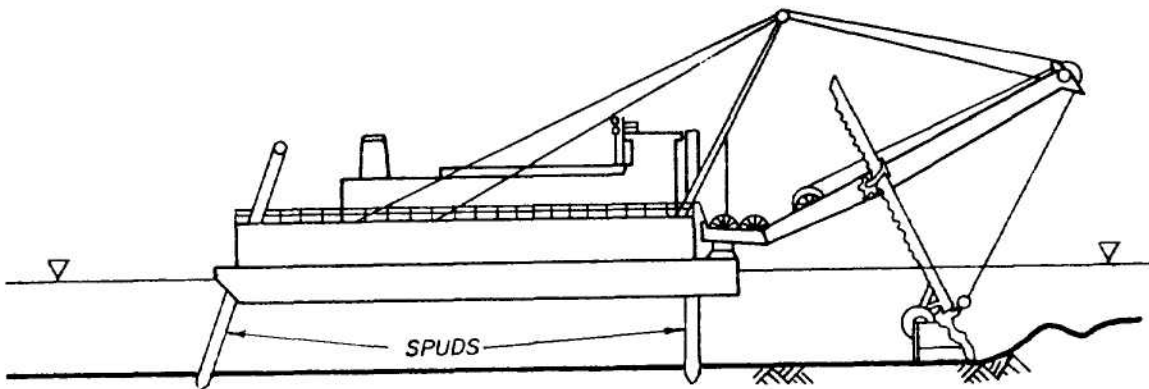

Figure 3-10. Dipper dredge.

increase digging power, the dredge barge is moored on powered spuds that transfer the weight of the forward section of the dredge to the bottom. Dipper dredges normally have a bucket capacity of 8 to 12 cu yd and a working depth of up to 50 ft. There is a great variability in production rates, but 30 to 60 cycles per hour is routinely achieved.

b. Description of Operation. The dipper type of dredge is not self-propelled but can move itself during the dredging process by manipulation of the spuds and the dipper arm. A typical sequence of operation is as follows :

(1) The dipper dredge, scow barges, and attendant plant are moved to the work site.

(2) The dredge is moved to the point where work is to start; part of the weight is placed on the forward spuds to provide stability.

(3) A scow barge is brought alongside and moored into place by winches and cables on the dipper dredge.

(4) The dredge begins digging and placing the material into the moored barge.

(5) When all the material within reach of the bucket is removed, the dredge is moved forward by lifting the forward spuds and maneuvering with the bucket and stern spud.

(6) The loaded barges are towed to the disposal area and emptied by bottom dumping if an open-water disposal area is used, or they are unloaded by mechanical or hydraulic equipment if diked disposal is required.

(7) These procedures are repeated until the dredging operation is completed.

c. Application. The best use of the dipper dredge is for excavating hard, compacted materials, rock, or other solid materials after blasting. Although it can be used to remove most bottom sediments, the violent action of this type of equipment may cause considerable sediment disturbance and resuspension during maintenance digging of fine-grained material. In addition, a significant loss of the fine-grained material will occur from the bucket during the hoisting process. The dipper dredge is most effective around bridges, docks, wharves, pipelines, piers, or breakwater structures because it does not require much area to maneuver; there is little danger of damaging the structures since the dredging process can be controlled accurately. No provision is made for dredged material containment or transport, so the dipper dredge must work alongside the disposal area or be accompanied by disposal barges during the dredging operation.

d. Advantages. The dipper dredge is a rugged machine that can remove bottom materials consisting of clay, hardpacked sand, glacial till, stone, or blasted rock material. The power that can be applied directly to the cutting edge of the bucket makes this type of dredge ideal for the removal

25 Mar 83

of hard and compact materials. It can also be used for removing old piers, breakwaters, foundations, pilings, roots, stumps, and other obstructions. The dredge requires less room to maneuver in the work area than most other types of dredges; the excavation is precisely controlled so that there is little danger of removing material from the foundation of docks and piers when dredging is required near these structures. Dipper dredges are frequently used when disposal areas are beyond the pumping distance of pipeline dredges, due to the fact that scow barges can transport material over long distances to the disposal area sites. The dipper type of dredge can be used effectively in refloating a grounded vessel. Because it can operate with little area for maneuvering, it can dig a shoal out from under and around a grounded vessel. The dipper dredge type of operation limits the volume of excess water in the barges as they are loaded. Dipper-dredged material can be placed in the shallow waters of eroding beaches to assist in beach nourishment.

e. Limitations. It is difficult to retain soft, semisuspended fine-grained materials in the buckets of dipper dredges. Scow-type barges are required to move the material to a disposal area, and the production is relatively low when compared to the production of cutterhead and dustpan dredges. The dipper dredge is not recommended for use in dredging contaminated sediments.

3-8. Bucket Dredges.

a. General. The bucket type of dredge is so named because it utilizes a bucket to excavate the material to be dredged (fig. 3-11). Different types of buckets can fulfill various types of dredging requirements. The buckets used include the clamshell, orangepeel, and dragline types and can be quickly changed to suit the operational requirements. The vessel can be positioned and moved within a limited area using only anchors; however, in most cases anchors and spuds are used to position and move bucket dredges. The material excavated is placed in scows or hopper barges that are towed to the disposal areas. Bucket dredges range in capacity from 1 to 12 cu yd. The crane is mounted on a flat-bottomed barge, on fixed-shore installations, or on a crawler mount. Twenty to thirty cycles per hour is typical, but large variations exist in production rates because of the variability in depths and materials being excavated. The effective working depth is limited to about 100 ft.

b. Description of Operation. The bucket type of dredge is not self-propelled but can move itself over a limited area during the dredging process by the manipulation of spuds and anchors. A typical sequence of operation is as follows:

(1) The bucket dredge, scows or hopper barges, and attendant plant are moved to the work site by a tug.

(2) The dredge is positioned at the location where work is to start and the anchors and spuds lowered into place.

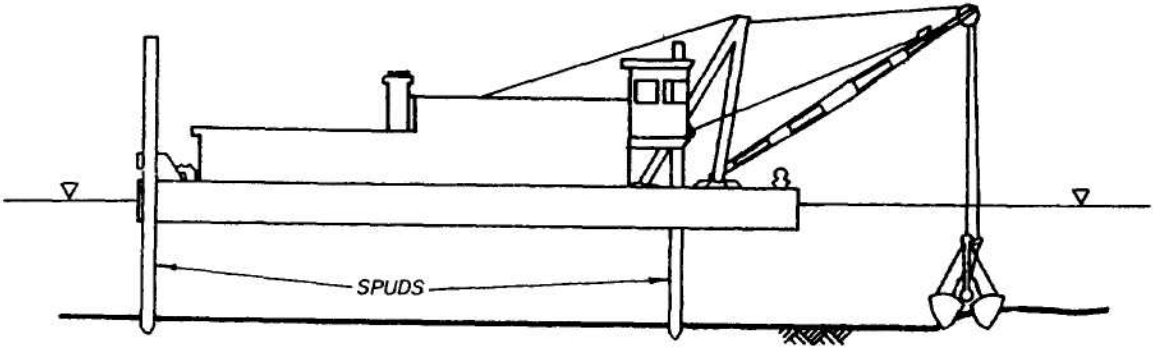

Figure 3-11. Bucket dredge.

(3) A scow or hopper barge is brought alongside and secured to the bucket dredge hull.

(4) The dredge begins the digging operation by dropping the bucket in an open position from a point above the sediment. The bucket falls through the water and penetrates into the bottom material. The sides or jaws of the bucket are then closed through the use of wire cables operated from the crane. As the sides of the bucket close, material is sheared from the bottom and contained in the bucket compartment. The bucket is raised above the water surface and swung to a point over the hopper barge. The material is then released into the hopper barge by opening the sides of the bucket.

(5) As material is removed from the bottom of the waterway to the desired depth at a given location, the dredge is moved to the next nearby location by using anchors. If the next dredging area is a significant distance away, the bucket dredge must be moved by a tug.

(6) The loaded barges are towed to the disposal area by a tug and emptied by bottom dumping if an open water disposal area is used. If a diked disposal area is used, the material must be unloaded using mechanical or hydraulic equipment.

(7) These procedures are repeated until the dredging operation is completed.

c. Application. Bucket dredges may be used to excavate most types of materials except for the most cohesive consolidated sediments and solid rock. Bucket dredges usually excavate a heaped bucket of material, but during hoisting turbulence washes away part of the load. Once the bucket clears the water surface, additional losses may occur through rapid drainage of entrapped water and slumping of the material heaped above the rim. Loss of material is also influenced by the fit and condition of the bucket, the hoisting speed, and the properties of the sediment. Even under ideal conditions, substantial losses of loose and fine sediments will usually occur. Because of this, special buckets must be used if the bucket dredge is to be considered for use in dredging contaminated sediments. To minimize the turbidity generated by a clamshell operation, watertight buckets have been developed (fig. 3-12). The edges seal when the bucket is closed and the top is covered to minimize loss of dredged material. Available sizes range from 2.6 to 26 cu yd. These buckets are best adapted for maintenance dredging of fine-grained material. A direct comparison of 1.3 cu-yd typical clamshell and watertight clamshell operations indicates that watertight buckets generate 30 to 70 percent less turbidity in the water column than typical buckets. This reduction is probably due primarily to the fact that leakage of dredged material from watertight buckets is reduced by approximately 35 percent. The bucket dredge is effective while working near bridges, docks, wharves, pipelines, piers, or breakwater structures because it does not require much area to maneuver; there is little danger of damaging the structures because the dredging process can be controlled accurately.

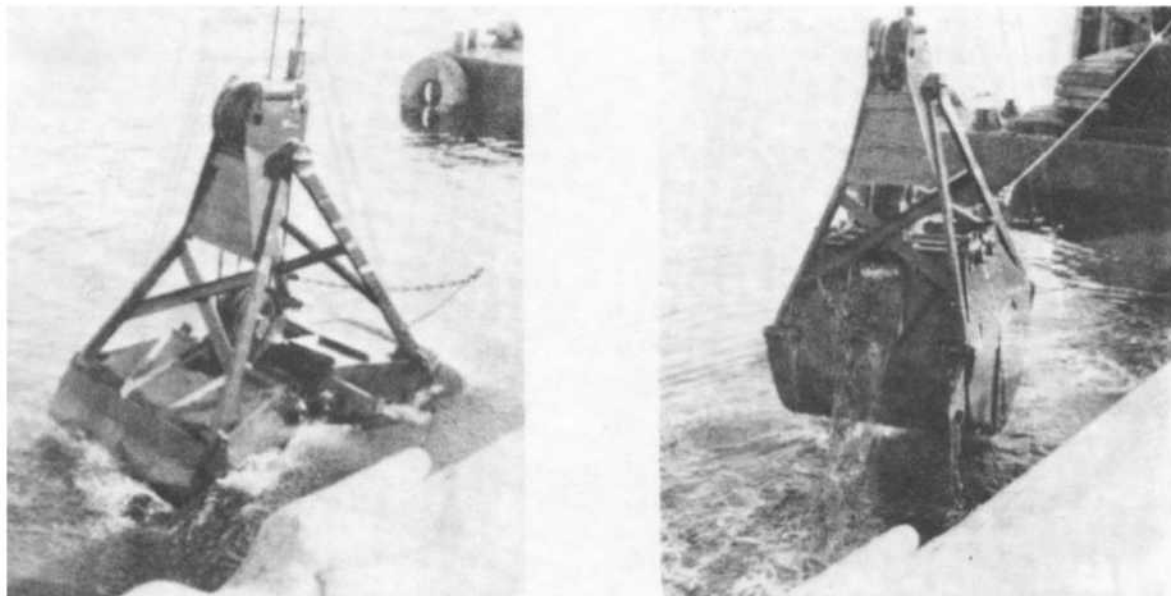

Figure 3-12. Open and closed positions of the watertight bucket.

d. Advantages. The bucket dredge has the same advantages cited for the dipper dredge, except that its capabilities in blasted rock and compact materials are somewhat less. The density of material excavated is about the same as the in-place density of the bottom material. Therefore, the volume of excess water is minimal, which increases the efficiency of operation in the transportation of material from the dredging area to the disposal area.

e. Limitations. The limitations of the bucket type of dredge are the same as those described for the dipper dredge (para 3-7e).

3-9. Special-Purpose Dredge

a. General. The Corps of Engineers Dredge CURRITUCK (fig. 3-13), assigned to the Wilmington District, is an example of a special-purpose type of dredge. Designed to work the same projects as sidecasting dredges, the CURRITUCK has the additional ability to completely remove material from the inlet complex and transport it to downdrift eroded beaches. It is a self-propelled split hull type of vessel, equipped with a self-leveling deck-house located at the stern, where all controls and machinery are housed. The vessel is hinged above the main deck so that the hull can open from bow to stern by means of hydraulic cylinders located in compartments forward and aft of the hopper section. The CURRITUCK has one hopper with a capacity of 315 cu yd. The hopper section is clearly visible to the operators in the pilot house, making production monitoring an easy task.

b. Description of Operation. The CURRITUCK operates in much the same way as a hopper dredge. The operator steers the vessel through the shoal

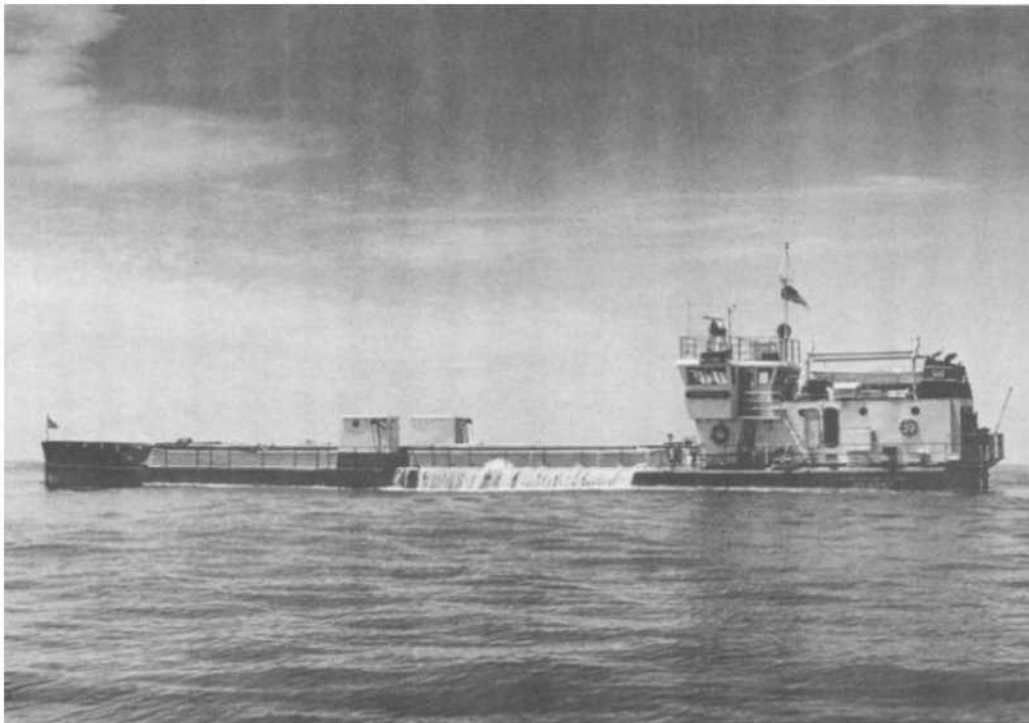

Figure 3-13. Corps special-purpose dredge.

areas of the channel. The dredge pumps, located in the compartments on each side of the hull, pump material through trailing dragarms into the hopper section. When an economic load is obtained, the dragarms are lifted from the bottom of the waterway and the dredge proceeds to the disposal area. A major difference between the operation of the CURRITUCK and that of a conventional hopper dredge is in the method of disposal; the CURRITUCK is designed to transport and deposit the dredged material close to the surf zone area.

c. Application. The CURRITUCK provides a sand-bypassing capability in addition to improving the condition of navigation channels. The CURRITUCK excavates material from navigation channels, transports it to downdrift eroded beaches, and releases it where it is needed to provide beach nourishment, rather than wasting it offshore. After the material has been deposited in the near-shore coastal areas, the dredge backs away and returns to the navigation channel.

d. Advantages. The CURRITUCK is an effective dredging tool for use in shallow-draft inlets. All of the dredged material is placed in the littoral zone. The CURRITUCK can also be used to supplement sidecasting dredges and to transport dredged materials from inlet channels to the near-shore areas of eroded beaches.

e. Limitations. The production rate of the CURRITUCK is limited by its small hopper capacity. Therefore, it is not effective on major navigation channels. In addition, when the flotation depths are minimal it is necessary to use a sidecasting dredge to provide access into the project.

3-10. Summary of Dredge Operating Characteristics. The important operating characteristics of each dredge presented in the preceding sections are summarized in table 3-5. In some cases, a wide range of values is given to account for the various sizes of plants within each class. In other instances, the information provides a qualitative judgement (high, low, average) of each dredge type's performance in a given area. Table 3-5 should be helpful in making quick assessments of the suitability of a given dredge type in a known physical setting.

3-11. Locations of Dredges in the United States. Figure 3-14 shows the distribution of dredging capability for the Corps and industry in the United States by region. Congress has determined (Public Law 95-269) that the Corps will operate a dredging fleet adequate to meet emergency and national defense requirements at home and abroad. This fleet will be maintained to technologically modern and efficient standards and will be kept in a fully operational status. The status of the United States dredging fleet as determined in the Corps of Engineers' National Dredging Study is comprehensively summarized in a paper of the same title (item 6). A detailed inventory of all dredges in the United States is published annually in World Dredging and Marine Construction (item 10). The designer can consult this source for information on the specific types of dredges available in the proposed project area.

Table 3-5. Summary of Dredge Operating Characteristics.^a

Dredge Type	Percent Solids		Turbidity Caused	Open-Water Operation	Vessel Draft ft	Approx. Range of Production Rates cu yd/hr	Dredging Depths ft		Limiting Wave Height ft	Limiting Current	Lateral Dredging Accuracy ft
	in Slurry by Weight ^b	in situ					Minimum	Maximum			
Dipper	in situ	high	yes ^d	e	30-500	0 ^f	50	<3 ^g	h	1/2	
Bucket	in situ	high ⁱ	yes ^d	e	30-500	0 ^f	100 ^j	<3 ^{g,k}	h	1	
Dustpan	10-20%	avg.	no	5-14	1200-5,700	5-14	50-60 ^l	<3	h	2-3	
Cutterhead	10-20%	avg.	yes ^d	3-14	25-10,000	3-14	12-65 ^l	<3	h	2-3	
Hopper	10-20%	avg.	yes	12-31	500-2,000	10-28	80	<7	h	10	
Sidecasting	10-20%	high	yes	5-9	325-650	6	25	<7	h	10	
Special-Purpose	10-20%	avg.	yes	5-8	250 avg.	8	20	<7	h	10	

^aPrepared by WES.

^bPercent solids could theoretically be 0, but these are normal working ranges. Percent solids = $\frac{\text{wt. of dry sediment}}{\text{wt. of wet slurry}}$.

^cVertical accuracies are generally within ±1 ft.

^dLimited operation in open water possible, depending on hull size and type and wave height.

^eDepends on floating structure; if barge-mounted, approximately 5- to 6-ft draft.

^fZero if used alongside of waterway; otherwise, draft of vessel will determine.

^gDepends on supporting vessel--usually barge-mounted.

^hLiterature implies that water current hinders dredging operations, but references avoid establishing maximum current limitations. For most dredges, limiting current is probably in the 3- to 5-knot range, with hopper and dustpan dredges able to work at currents of perhaps 7 knots.

ⁱLow, if watertight bucket is used.

^jDemonstrated depth; theoretically could be used much deeper.

^kTheoretically unaffected by wave height; digging equipment not rigid.

^lWith submerged dredge pumps, dredging depths have been increased to 100 ft or more.

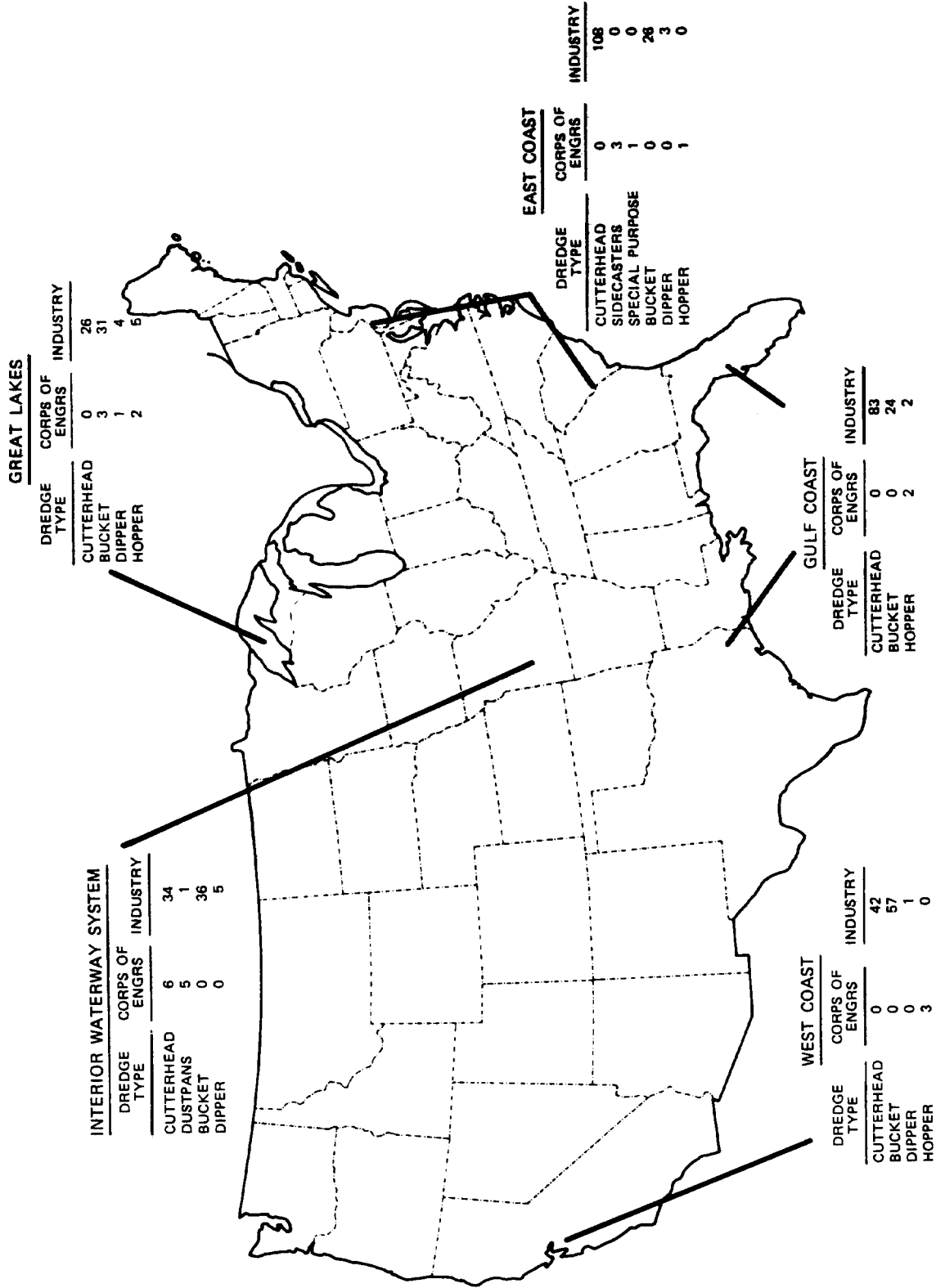

Figure 3-14. Distribution of dredging capability for the Corps and industry.
(data obtained from item 10)

3-12. Agitation Dredging Techniques.

a. General. Agitation dredging is the process of removing bottom material from a selected area by using equipment to raise it in the water column and allowing currents to carry it from the project area. In the most detailed study available on agitation dredging techniques, Richardson (item 7) evaluated past agitation dredging projects and presented guidelines and recommendations for using agitation dredging. Two distinct phases are involved in agitation dredging: (1) suspension of bottom sediments by some type of equipment, and (2) transport of the suspended material by currents. The main purpose of the equipment is to raise bottom material in the water column. Natural currents are usually involved in transporting the material from the dredging site, although the natural currents may be augmented with currents generated by the agitation equipment. Agitation dredging is accomplished by methods such as hopper dredge agitation, prop-wash, vertical mixers or air bubble, rakes or drag beams, and water jets. Based on the work done by Richardson (item 7), only hopper dredge, prop-wash, and rake or beam dragging agitation justify more detailed discussion in this EM.

b. Objectives. The main objective of agitation dredging is the removal of bottom material from a selected area. If the material is suspended but redeposits shortly in the same area, only agitation (not agitation dredging) has been accomplished. The decision to use agitation dredging should be based primarily on the following factors:

(1) Technical feasibility. The equipment to generate the required level of agitation must be available, and the agitated material must be carried away from the project area by currents.

(2) Economic feasibility. Agitation dredging must be determined the most cost-effective method for achieving the desired results; it should not affect the costs of other dredging projects downstream by increasing dredging volumes.

(3) Environmental feasibility. Agitation dredging should not cause unacceptable environmental impacts.

c. Hopper Dredge Agitation.

(1) General. Refer to para 3-3a for a general description of hopper dredges. In agitation dredging, hopper capacity is of secondary importance compared with pumping rates, mobility, and overflow provisions.

(2) Description of operation. The general operation of a hopper dredge is discussed in para 3-3b. In hopper dredge agitation, the conventional dredge-haul-dump operating mode is modified by increasing the dredging mode and reducing the haul-dump mode. It has been reported that hopper dredge agitation can allow a project to be maintained with a dredge which is relatively small compared with the size dredge required for a conventional dredge-haul-dump operation. Hopper dredge agitation is of

two types: (a) intentional agitation produced by hopper overflow; and (b) auxiliary agitation caused by dragheads and propeller wash. Since the latter is present in all hopper dredge operations and since it is difficult to quantify separately from hopper overflow, both types are measured together when reporting hopper dredge agitation effectiveness.

(3) Application. Agitation hopper dredging can perform the same maintenance functions as conventional hopper dredging if the following conditions are satisfied: (a) sediments are fine-grained and loosely consolidated, (b) currents are adequate to remove the agitated sediments from the project area, and (c) no unacceptable environmental impact results from the agitation dredging.

(4) Advantages. Because currents, not equipment, transport most of the sediment from the project area during agitation hopper dredging, the following advantages are realized: (a) hopper dredge agitation costs can be several times less per cubic yard than hopper dredge hauling costs and (b) smaller hopper dredges can be used to maintain certain projects.

(5) Limitations. Hopper dredge agitation should be applied only to specific dredging sites and not used as a general method to maintain large areas. The following limitations must be noted when considering this dredging technique for use at a site: (a) hopper dredge agitation cannot be used in environmentally sensitive areas where unacceptable environmental impacts may occur and (b) sediments and current conditions must be suitable for agitation dredging.

d. Prop-Wash Agitation.

(1) General. Prop-wash agitation dredging is performed by vessels especially designed or modified to direct propeller-generated currents into the bottom shoal material. The agitated material is suspended in the water column and carried away by a combination of natural currents and prop-wash currents. Unintentional prop-wash agitation dredging often occurs while vessels move through waterways. This type of sediment resuspension is uncontrolled and is often considered undesirable.

(2) Description of operation. The prop-wash vessel performs best when work begins at the upstream side of a shoal and proceeds downstream with the prop-wash-generated current directed downstream. The vessel is anchored in position, and prop-wash-generated currents are directed into the shoal material for several minutes. The vessel is then repositioned and the process is repeated.

(3) Application. Prop-wash agitation dredging has been successfully used in coastal harbors, river mouths, river channels, and estuaries. It is a method intended for use in loose sands and in maintenance dredged material consisting of uncompacted clay and silt. Cementing, cohesion, or compaction of the bottom sediment can make prop-wash agitation dredging difficult to perform. Waves may cause anchoring problems with the agitation vessel. Optimum water depths for prop-wash agitation dredging in sand

are between two and three times the agitation vessel's draft. Based on studies by Richardson (item 7), the average performance of vessels specially designed for prop-wash agitation range from 200 to 300 cu yd/hr in sand and are a little higher for fine-grained material.

(4) Advantages. The major advantages of prop-wash agitation dredging are related to economics. In some areas, prop-wash agitation dredging has been found to cost 40 to 90 percent less per cubic yard dredged than conventional dredging methods.

(5) Limitations. The limitations on prop-wash agitation dredging are as follows: (a) prop-wash agitation seems best suited for areas with little or no wave action, (b) prop-wash agitation should be applied in water depths less than four times the agitation vessel's draft, and (c) the sediments must be loose sands, silt, or clay.

e. Rakes and Drag Beams. Rakes, drag beams, and similar devices work by being pulled over the bottom (usually by a vessel), mechanically loosening the bottom material, and raising it into the water column to be carried away by natural currents. Since rakes and drag beams do not produce currents of their own and since they do not resuspend material as much as loosen it, these devices must be used in conjunction with currents strong enough to transport the loosened material away from the shoaling site; in addition, the vessel towing one of these devices may provide some resuspension and transport by its propwash. A wide range of dredging rates have been reported for agitation dredging by rakes and beams. Little value would be obtained by reporting these rates because they are highly dependent upon site conditions; however, it has been reported that the cost of agitation dredging by rakes and beams can be less than 10 percent of the cost for conventional dredging. Data show a definite correlation between dragging speed and dredging rate. The advantages and limitations for rake and drag beams are similar to those reported for other agitation dredging techniques.

f. Environmental Considerations. The environmental considerations discussed in Chapter 4 also apply to all agitation dredging techniques. The properties of sediments affect the fate of contaminants, and the short- and long-term physical and chemical conditions of the sediments at the agitation dredging site influence the environmental consequences of contaminants. These factors should be considered in evaluating the environmental risk of a proposed agitation dredging technique.

3-13. Advances in Dredging Technology. Advanced dredging technologies are generally directed toward one or more of the following areas of improvement: greater depth capability; greater precision, accuracy, and control over the dredging process; higher production efficiency; and decreased environmental harm. Following are brief descriptions of the major recent innovations in production dredging:

- a. Ladder-mounted submerged pumps for higher production.

- b. Improved designs of dredging heads to minimize material resuspension.
- c. Use of spud barges aft of the dredge to extend hull length and increase dredge swing. This will increase production efficiency of cutter-head dredges.
- d. Longer ladders, connected further aft on the dredge hull to increase depth and permit greater control.
- e. Tandem pump systems for greater production efficiency and reliability.
- f. Better hull designs equipped with liquid stabilizing systems (motion compensators) to allow use in heavier seas.
- g. Improved production instrumentation to monitor flow rates, densities, cumulative production, etc.
- h. Improved navigation, positioning, and bottom profiling instrumentation. The state of the art includes advanced laser, electronic, and acoustical systems.
- i. Closed-bucket modifications to reduce loss of fines and liquid from bucket dredges.
- j. Depth and swing indicators for mechanical dredges.
- k. Use of silt curtains during dredging and open-water disposal to restrict turbidity plumes and, in the case of contaminated materials, limit the added dispersion due to dredging.

3-14. Environmental Considerations. The adverse environmental effects normally associated with dredging operations are increases in turbidity, resuspension of contaminated sediments, and decreases in dissolved oxygen. Selection and operation of the type of dredge plant as well as the type of sediment being dredged affect the degree of adverse impacts during dredging. Investigations which have been conducted by WES under the DMRP have studied the environmental effects caused by dredging and disposal operations. The results of these studies have been published as WES Technical Reports. Guidance on the environmental aspects of dredging and disposal is presented in Chapter 4.

CHAPTER 4
DISPOSAL ALTERNATIVES

4-1. Introduction.

a. While selection of proper dredging equipment and techniques is essential for economic dredging, the selection of a disposal alternative is of equal or greater importance in determining viability of the project, especially from the environmental standpoint. There are three major disposal alternatives available:

- (1) Open-water disposal.
- (2) Confined disposal.
- (3) Habitat development.

Each of the major disposal alternatives involves its own set of unique considerations, and selection of a disposal alternative should be made based on both economic and environmental considerations.

b. This chapter describes considerations in evaluation of disposal alternatives, primarily from an environmental standpoint. Sections on evaluation of pollution potential and sediment resuspension due to dredging apply to all disposal alternatives, while separate sections describe considerations of each of the three major disposal alternatives.

Section I. Evaluation of Dredged Material Pollution Potential

4-2. Influence of Disposal Conditions on Environmental Impact.

a. As discussed in WES TR DS-78-6, the properties of a dredged sediment affect the fate of contaminants, and the short- and long-term physical and chemical environment of the dredged material at the disposal site influences the environmental consequences of contaminants. These factors should be considered in evaluating the environmental risk of a proposed disposal method for contaminated sediment. The processes involved with release or immobilization of most sediment-associated contaminants are regulated to a large extent by the physical-chemical environment and the related bacteriological activity associated with the dredged material at the disposal site. Important physical-chemical parameters include pH, oxidation-reduction conditions, and salinity. Where the physical-chemical environment of a contaminated sediment is altered by disposal, chemical and biological processes important in determining environmental consequences of potentially toxic materials may be affected.

b. The major sediment properties that will influence the reaction of dredged material with contaminants are the amount and type of clay; organic matter content; amount and type of cations and anions associated with the sediment; the amount of potentially reactive iron and manganese; and the oxidation-reduction, pH, and salinity conditions of the sediment. Although each of these sediment properties is important, much concerning the release

of contaminants from sediments can be inferred from the clay and organic matter content, initial and final pH, and oxidation-reduction conditions. Much of the dredged material removed during harbor and channel maintenance dredging is high in organic matter and clay and is both biologically and chemically active. It is usually devoid of oxygen and may contain appreciable sulfide. These sediment conditions favor effective retention of many contaminants, provided the dredged materials are not subject to mixing, resuspension, and transport. Sandy sediments low in organic matter content are much less effective in retaining metal and organic contaminants. These materials tend not to accumulate contaminants unless a contamination source is nearby. Should contamination of these sediments occur, potentially toxic substances may be readily released upon mixing in a water column, or by leaching and possibly plant uptake under intertidal or upland disposal conditions.

c. Many contaminated sediments are reducing and near neutral in pH, initially. Disposal into quiescent waters will generally maintain these conditions and favor contaminant retention. Certain sediments (noncalcareous and containing appreciable reactive iron and particularly reduced sulfur compounds) may become moderately to strongly acid upon gradual drainage and subsequent oxidation as may occur under upland disposal conditions. This altered disposal environment greatly increases the potential for releasing potentially toxic metals. In addition to the effects of pH changes, the release of most potentially toxic metals is influenced to some extent by oxidation-reduction conditions, and certain of the metals can be strongly affected by oxidation-reduction conditions. Thus, contaminated sandy, low organic-matter-content sediments pose the greatest potential for release of contaminants under all conditions of disposal. Sediments which tend to become strongly acid upon drainage and long-term oxidation also pose a high environmental risk under some disposal conditions. The implications of the influence of disposal conditions on contaminant mobility are discussed below.

4-3. Methods of Characterizing Pollution Potential.

a. Bioassay. Bioassay tests are used to determine the effects of a contaminant(s) on biological organisms of concern. They involve exposure of the test organisms to dredged material (or some fraction such as the elutriate) for a specified period of time, followed by determination of the response of the organisms. The most common response of interest is death. Often the tissues of organisms exposed to dredged material are analyzed chemically to determine whether they have incorporated, or bioaccumulated, any contaminants from the dredged material. Bioassays provide a direct indication of the overall biological effects of dredged material. They reflect the cumulative influence of all contaminants present, including any possible interactions of contaminants. Thus, they provide an integrated measurement of potential biological effects of a dredged material discharge. For precisely these reasons, however, a bioassay cannot be used to identify the causative agent(s) of impact in a dredged material. This is of interest, but is seldom of importance, since usually the dredged material cannot be treated to remove the adverse components even if they could be identified. Dredged material bioassay techniques for aquatic animals have been

implemented in the ocean-dumping regulatory program for several years (item 1) and are easily adapted for use in fresh water. Dredged material bioassays for wetland and terrestrial plants have also been developed (item 2) and are coming into ever-wider use.

b. Water Column Chemistry. Chemical constituents contained in or associated with sediments are unequally distributed among different chemical forms depending on the physical-chemical conditions in the sediments and the overlying water. When contaminants introduced into the water column become fixed into the underlying sediments, they rarely if ever become part of the geological mineral structure of the sediment. Instead, these contaminants remain dissolved in the sediment interstitial water, or pore water, become absorbed or adsorbed to the sediment ion exchange portion as ionized constituents, form organic complexes, and/or become involved in complex sediment oxidation-reduction reactions and precipitations. The fraction of a chemical constituent that is potentially available for release to the water column when sediments are disturbed is approximated by the interstitial water concentrations and the loosely bound (easily exchangeable) fraction in the sediment. The elutriate test is a simplified simulation of the dredging and disposal process wherein predetermined amounts of dredging site water and sediment are mixed together to approximate a dredged material slurry. The elutriate is analyzed for major dissolved chemical constituents deemed critical for the proposed dredging and disposal site after taking into account known sources of discharges in the area and known characteristics of the dredging and disposal site. Results of the analysis of the elutriate approximate the dissolved constituent concentration for a proposed dredged material disposal operation at the moment of discharge. These concentrations can be compared to water quality standards and mixing zone considerations to evaluate the potential environmental impact of the proposed discharge activity in the discharge area.

c. Total or Bulk Sediment Chemistry. The results of these analyses provide some indication of the general chemical similarity between the sediments to be dredged and the sediments at the proposed disposal site. The total composition of sediments, when compared with natural background levels at the site, will also, to some extent, reflect the inputs to the waterway from which they were taken and may sometimes be used to identify and locate point source discharges. Since chemical constituents are partitioned among various sediment fractions, each with its own mobility and biological availability, a total sediment analysis is not a useful index of the degree to which dredged material disposal will affect water quality or aquatic organisms. Total sediment analysis results are further limited because they cannot be compared to any established water quality criteria in order to assess the potential environmental impact of discharge operations. This is because the water quality criteria are based on water-soluble chemical species, while chemical constituents associated with dredged material suspensions are generally in particulate/solid-phase forms or mineralogical forms that have markedly lower toxicities, mobilities, and chemical reactivities than the solution-phase constituents. Consequently, little information about the biological effects of solid-phase and mineral constituents that make up the largest fraction of dredged material can be gained from total or bulk sediment analysis.

Section II. Sediment Resuspension Due to Dredging

4-4. Factors Influencing Dredging Turbidity.

a. Occurrence and Extent. The nature, degree, and extent of sediment suspension around a dredging or disposal operation are controlled by many factors, as discussed in WES TR DS-78-13. Chief among these are: the particle size distribution, solids concentration, and composition of the dredged material; the dredge type and size, discharge/cutter configuration, discharge rate, and solids concentration of the slurry; operational procedures used; and finally the characteristics of the hydraulic regime in the vicinity of the operation, including water composition, temperature and hydrodynamic forces (i.e., waves, currents, etc.) causing vertical and horizontal mixing. The relative importance of the different factors may vary significantly from site to site.

b. Hopper Dredge. Resuspension of fine-grained maintenance dredged material during hopper dredging operations is caused by the dragheads as they are pulled through the sediment, turbulence generated by the vessel and its prop wash, and overflow of turbid water during hopper filling operations. During the filling operation, dredged material slurry is often pumped into the hoppers after they have been filled with slurry in order to maximize the amount of solid material in the hopper. The lower density, turbid water at the surface of the filled hoppers overflows and is usually discharged through ports located near the waterline of the dredge. In the vicinity of hopper dredges during maintenance operations, a near-bottom turbidity plume of resuspended bottom material may extend 2300 to 2400 ft downcurrent from the dredge. In the immediate vicinity of the dredge, a well-defined, upper plume is generated by the overflow process. Approximately 1000 ft behind the dredge the two plumes merge into a single plume (fig. 4-1). Suspended solid concentrations above ambient may be as high as

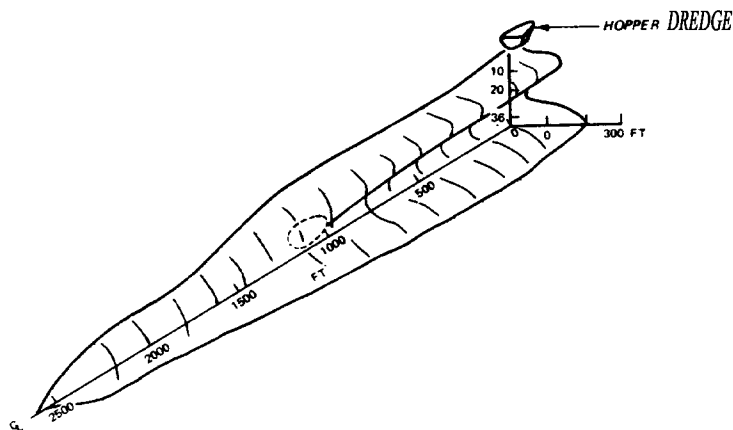

Figure 4-1. Hypothetical suspended solids plume downstream of a hopper dredge operation with overflow in San Francisco Bay (all distances in feet)*

several tens of parts per thousand (grams per litre) near the discharge port and as high as a few parts per thousand near the draghead. Turbidity levels in the near-surface plume appear to decrease exponentially with increasing distance from the dredge due to settling and dispersion, quickly reaching concentrations less than 1 ppt. However, plume concentrations may exceed background levels even at distances in excess of 4000 ft.

c. Bucket or Clamshell Dredge. The turbidity generated by a typical clamshell operation can be traced to sediment resuspension occurring when the bucket impacts on and is pulled off the bottom, turbid water spills out of the bucket or leaks through openings between the jaws, and material is inadvertently spilled during the barge loading operation. There is a great deal of variability in the amount of material resuspended by clamshell dredges due to variations in bucket size, operating conditions, sediment types, and hydrodynamic conditions at the dredging site. Based on limited measurements, it appears that, depending on current velocities, the turbidity plume downstream of a typical clamshell operation may extend approximately 1000 ft at the surface and 1600 ft near the bottom. Maximum concentrations of suspended solids in the surface plume should be less than 0.5 ppt in the immediate vicinity of the operation and decrease rapidly with distance from the operation due to settling and dilution of the material. Average water-column concentrations should generally be less than 0.1 ppt. The near-bottom plume will probably have a higher solids concentration, indicating that resuspension of bottom material near the clamshell impact point is probably the primary source of turbidity in the lower water column. The visible near-surface plume will probably dissipate rapidly within an hour or two after the operation ceases.

d. Cutterhead or Hydraulic Pipeline Dredge. Most of the turbidity generated by a cutterhead dredging operation is usually found in the vicinity of the cutter. The levels of turbidity are directly related to the type and quantity of material cut, but not picked up, by the suction. The ability of the dredge's suction to pick up bottom material determines the amount of cut material that remains on the bottom or suspended in the water column. In addition to the dredging equipment used and its mode of operation, turbidity may be caused by sloughing of material from the sides of vertical cuts; inefficient operational techniques; and the prop wash from the tenders (tugboats) used to move pipeline, anchors, etc., in the shallow water areas outside the channel. Based on limited field data collected under low current conditions, elevated levels of suspended material appear to be localized in the immediate vicinity of the cutter as the dredge swings back and forth across the dredging site. Within 10 ft of the cutter, suspended solids concentrations are highly variable but may be as high as a few tens of parts per thousand; these concentrations decrease exponentially from the cutter to the water surface. Near-bottom suspended solids concentrations may be elevated to levels of a few tenths of a part per thousand at distances of less than 1000 ft from the cutter.

Section III. Open-Water Disposal

4-5. Behavior of Discharges from Various Types of Dredges.

a. Hopper Dredge. The characteristics and operation of hopper dredges are discussed in para 3-3 of this manual. When the hoppers have been filled as described, the dragarms are raised and the hopper dredge proceeds to the disposal site. At the disposal site, hopper doors in the bottom of the ship's hull are opened and the entire hopper contents are emptied in a matter of seconds; the dredge then returns to the dredging site to reload. This procedure produces a series of discrete discharges at intervals of perhaps one to several hours. Upon release from the hopper dredge at the disposal site, the dredged material falls through the water column as a well-defined jet of high-density fluid which may contain blocks of solid material. Ambient water is entrained during descent. After it hits bottom, some of the dredged material comes to rest. Some material enters the horizontally spreading bottom surge formed by the impact and is carried away from the impact point until the turbulence of the surge is sufficiently reduced to permit its deposition.

b. Bucket or Clamshell Dredge. Bucket dredges remove the sediment being dredged at nearly its in situ density and place it in barges or scows for transportation to the disposal area, as described in para 3-8. Although several barges may be used so that the dredging is essentially continuous, disposal occurs as a series of discrete discharges. The dredged material may be a slurry similar to that in a hopper dredge, but often sediments dredged by clamshell remain in fairly large consolidated clumps and reach the bottom in this form. Whatever its form, the dredged material descends rapidly through the water column to the bottom, and only a small amount of the material remains suspended.

c. Cutterhead or Hydraulic Pipeline Dredge. The operation of a cutterhead dredge, described in para 3-4, produces a slurry of sediment and water discharged at the disposal site in a continuous stream. As the dredge progresses up the channel, the pipeline is moved periodically to keep abreast of the dredge. The discharged dredged material slurry is generally dispersed in three modes. Any coarse material, such as gravel, clay balls, or coarse sand, will immediately settle to the bottom of the disposal area and usually accumulates directly beneath the discharge point. The vast majority of the fine-grained material in the slurry also descends rapidly to the bottom in a well-defined jet of high-density fluid, where it forms a low-gradient circular or elliptical fluid mud mound. Approximately 1 to 3 percent of the discharged material is stripped away from the outside of the slurry jet as it descends through the water column and remains suspended as a turbidity plume.

4-6. Dredged Material Dispersion at the Discharge Site.

a. Water-Column Turbidity. The levels of suspended solids in the water column around a discharge operation generally range from a few hundredths to a few tenths of a part per thousand. Concentrations are highest near the discharge point and rapidly decrease with increasing distance

downstream from the discharge point and laterally away from the plume center line due to settling and horizontal dispersion of the suspended solids. Concentrations also decrease rapidly between each discrete hopper or barge discharge and after a pipeline is shut down or moved to a new location. Under tidal conditions, the plume will be subject to the tidal dynamics of the particular bay, estuary, or river mouth in which the dredging activity takes place. Many of the Corps projects have been studied in physical hydraulic models, and estimates of plume excursion can be made from their model reports. Rough estimates can be made from numerical models. Mathematical model result can be materially improved when calibrated by physical and/or prototype data; except under very simple conditions, all models have to be verified with prototype or prototype-derived data. In rivers where the flow is unidirectional, the plume length is controlled by the strength of the current and the settling properties of the suspended material. In both estuarine and riverine environments the natural levels of turbulence and the fluctuations in the rate of slurry discharge will usually cause the idealized teardrop-shaped plume to be distorted by gyres or eddylike patterns, as in figure 4-2.

b. Fluid Mud. A small percentage of the fine-grained dredged material slurry discharged during open-water disposal is dispersed in the water column as a turbidity plume; however, the vast majority rapidly descends to the bottom of the disposal area where it accumulates under the discharge point in the form of a low-gradient fluid mud mound overlying the existing bottom sediment, as shown in figure 4-3. If the discharge point of a hydraulic pipeline dredge is moved as the dredge advances, a series of mounds will develop. The majority of the mounded material is usually high-density (nonflowing) fluid mud that is covered by a surface layer of low-density (flowing or nonflowing) fluid mud. Under quiescent conditions, more than 98 percent of the sediment in the mudflow remains in the fluid mud layer at concentrations greater than 10 ppt, while the remaining 2 percent may be resuspended by mixing with the overlying water at the fluid mud surface. Fluid mud will tend to flow downhill as long as the bottom slope is approximately 1 percent or greater. A study of hopper dredge disposal at Carquinez Strait, San Francisco Bay, showed concentrations of dredged material in the water column were generally less than 0.2 ppt above background and persisted for only a few tens of minutes. However, 3 to 8 ft above the bottom, concentrations reached 20 ppt in a fluid mud layer. Similar occurrences of low suspended sediment concentrations in the water column with concentrations on the order of several tens of parts per thousand just above the bottom, as in figure 4-4, have been discussed for pipeline dredge discharges in WES TR DS-78-13. These conditions persist for the duration of the disposal operation at the site and for varying times thereafter as the material consolidates to typical sediment density.

c. Mounding. If bottom slopes are not great enough to maintain mudflows, the fluid mud will stop and begin to consolidate. When suspended sediment concentrations exceed 200 ppt the fluid mud can no longer flow freely but will accumulate around the discharge point in a low-gradient (e.g., 1:500) fluid mud mound. At the water column/fluid mud interface, the solids concentration increases very abruptly from perhaps a few tenths of a part per thousand in the water to approximately 200 ppt in the fluid

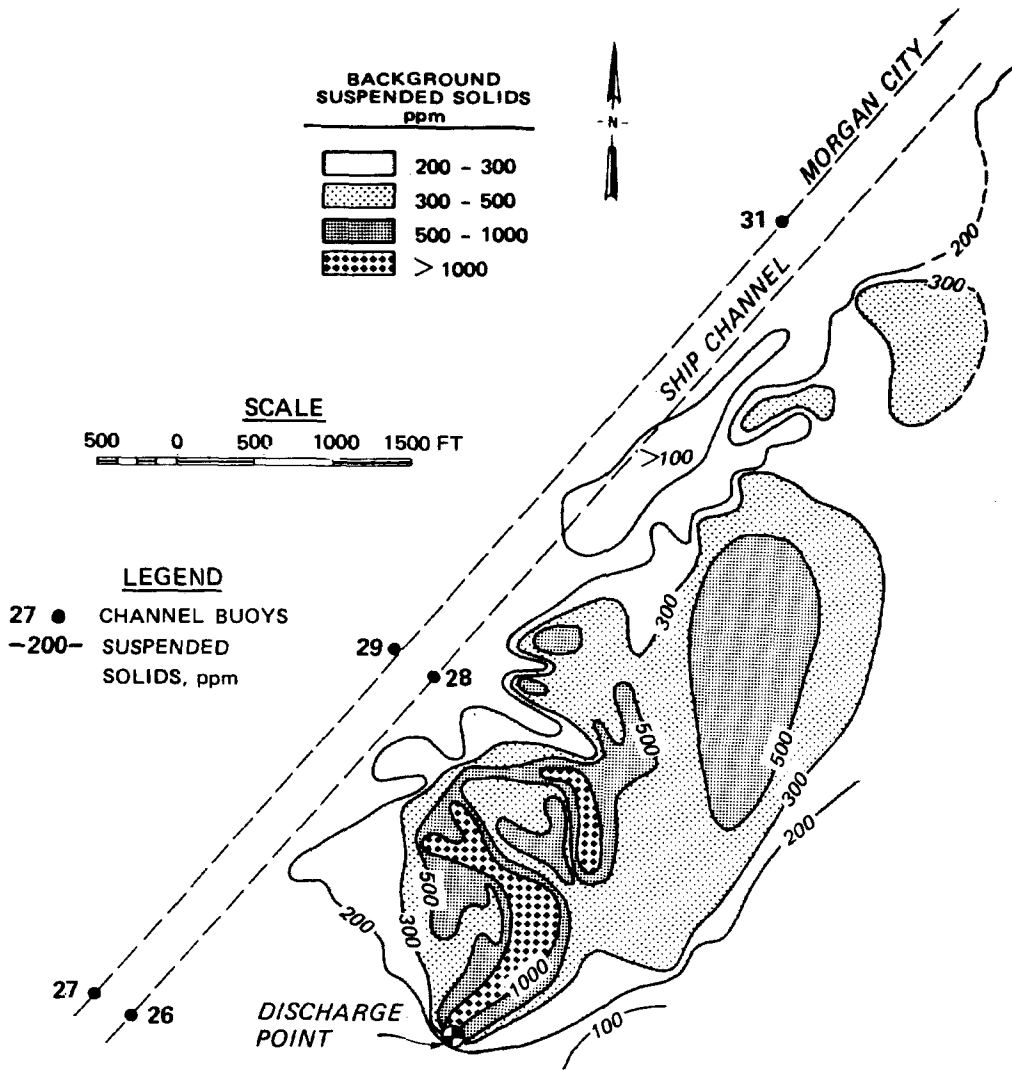

Figure 4-2. Middepth (3.0 ft) turbidity plume generated by a 28-in. pipeline disposal operation in the Atchafalaya Bay. Current flow is generally toward the northeast.

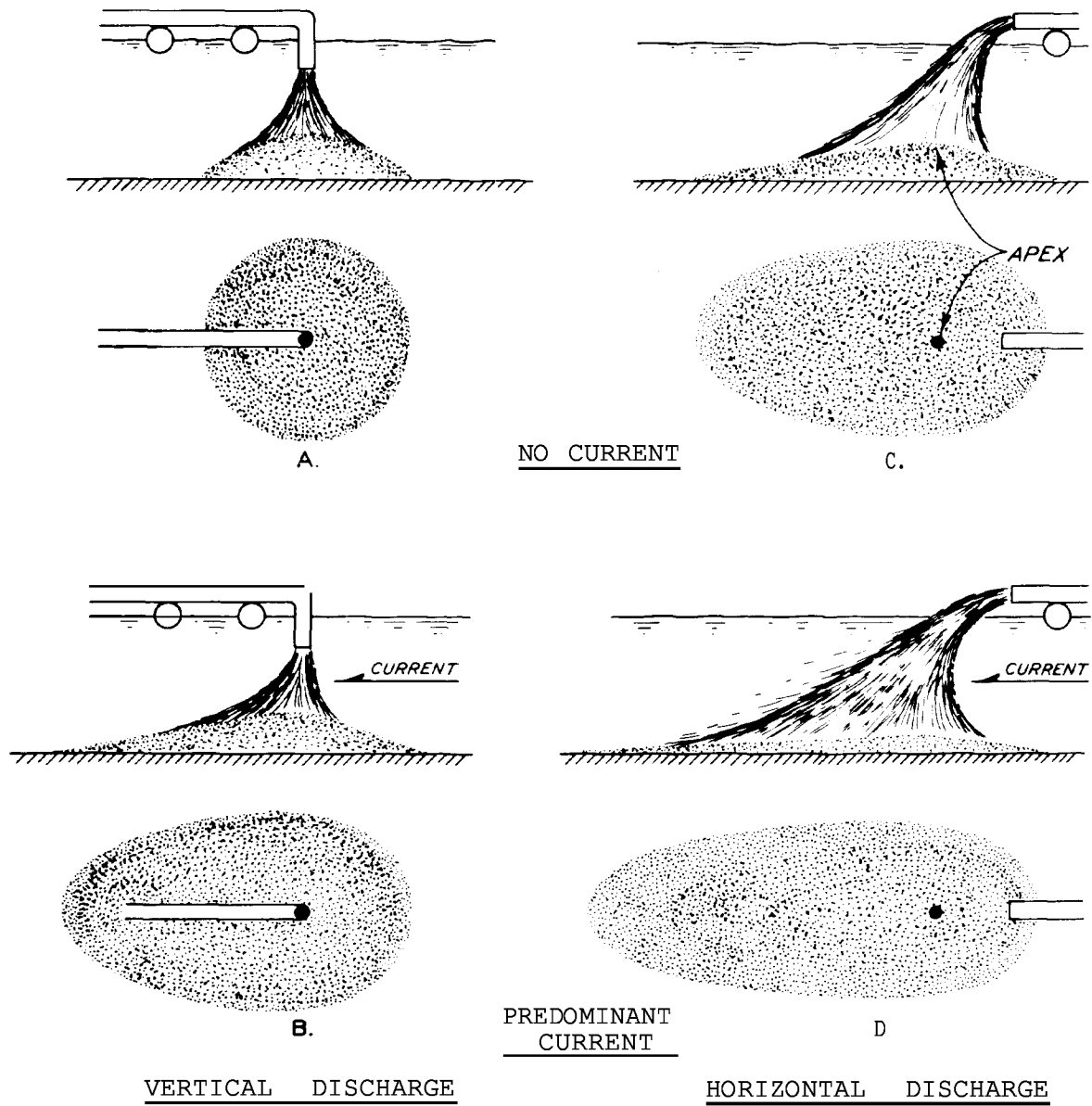

Figure 4-3. Effect of discharge angle and predominant current direction on the shape of a fluid mud mound.

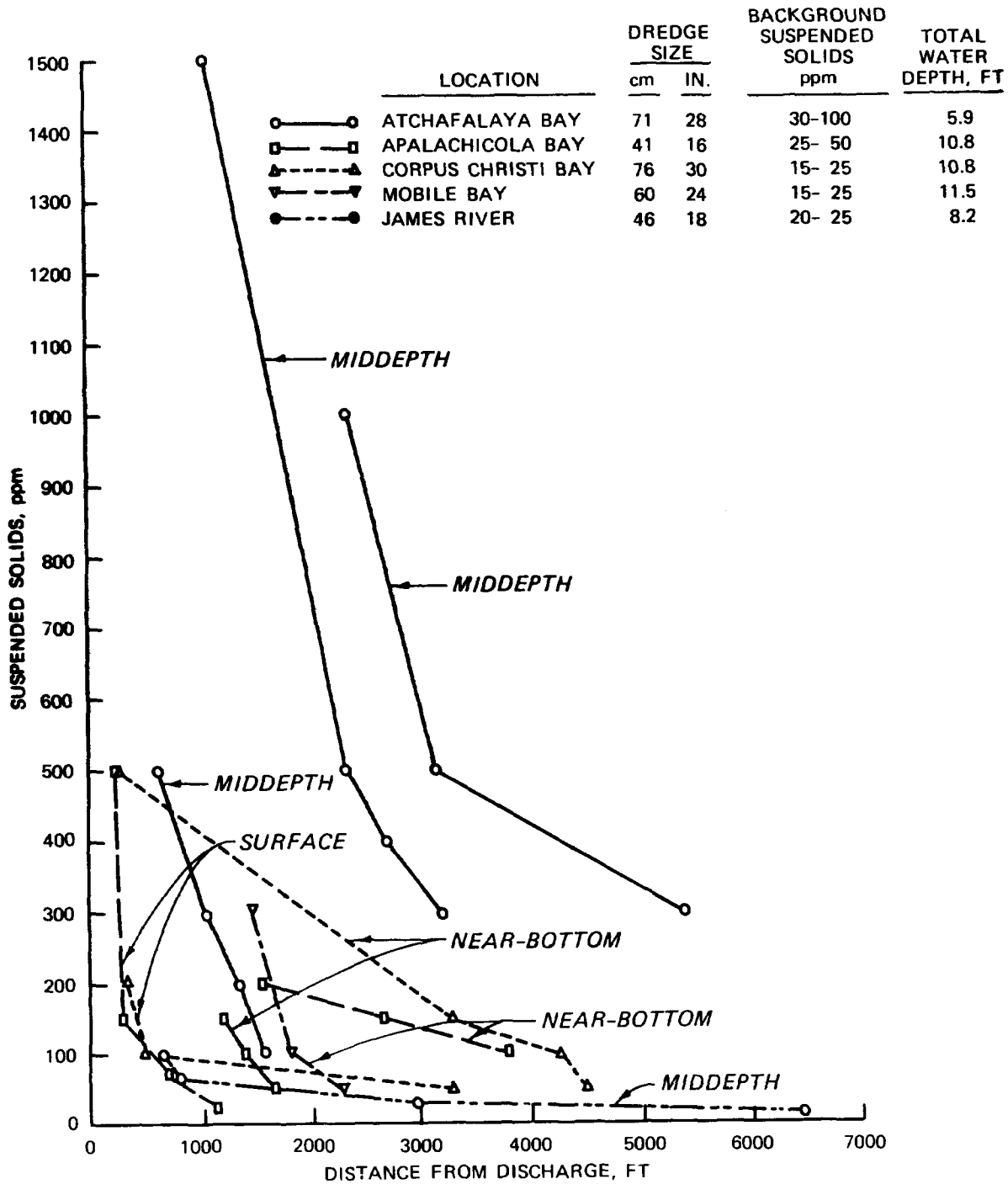

Figure 4-4. Relationship between suspended solids concentration along the plume center line and distance downcurrent from several open-water pipeline disposal operations measured at the indicated water depths,

mud. The solids concentration within the fluid mud increases above 200 ppt at a slower rate with depth until it reaches normal sediment densities. Deeper layers of fluid mud reach their final degree of consolidation more rapidly than thinner ones. Depending on the thickness of the fluid mud and its sedimentation/consolidation characteristics, complete consolidation of a fluid mud mound may require from one to several years. In those situations where material dredged by bucket or clamshell is of slurry consistency, the above description is generally applicable. More commonly, however, muddy sediments dredged by a clamshell remain in large clumps and descend to the bottom in this form. These may break apart somewhat on impact; but such material tends to accumulate in irregular mounds under the discharge vessel, rather than move outward from the discharge point. Whatever the dredging method, sandy sediments tend to mound directly beneath the discharge pipe or vessel.

d. Special Circumstances. Knowledge of the behavior of discharged dredged material allows control of the dispersion of the material at the disposal site. When minimum dispersal is desired, the dredged material can be discharged into old underwater borrow pits, sand or gravel excavation sites, etc. Such deposits may be further isolated from the overlying water column by covering with a layer of uncontaminated sediment. It is also possible to place such a covering, or "cap," over dredged material discharged onto a flat bottom.

4-7. Environmental Impacts in the Water Column.

a. Contaminants. Although the vast majority of heavy metals, nutrients, and petroleum and chlorinated hydrocarbons are usually associated with the fine-grained and organic components of the sediment (see WES TR DS-78-4), there is no biologically significant release of these chemical constituents from typical dredged material to the water column during or after dredging or disposal operations. Levels of manganese, iron, ammonium nitrogen, orthophosphate, and reactive silica in the water column may be increased somewhat for a matter of minutes over background conditions during open-water disposal operations; however, there are no persistent well-defined plumes of dissolved metals or nutrients at levels significantly greater than background concentrations.

b. Turbidity. There are now ample research results indicating that the traditional fears of water-quality degradation resulting from the re-suspension of dredged material during dredging and disposal operations are for the most part unfounded. The possible impact of depressed levels of dissolved oxygen has also been of some concern, due to the very high oxygen demand associated with fine-grained dredged material slurry. However, even at open-water pipeline disposal operations where the dissolved oxygen decrease should theoretically be greatest, near-surface dissolved oxygen levels of 8 to 9 ppm will be depressed during the operation by only 2 to 3 ppm at distances of 75 to 150 ft from the discharge point. The degree of oxygen depletion generally increases with depth and increasing concentration of total suspended solids; near-bottom levels may be less than 2 ppm. However, dissolved oxygen levels usually increase with increasing distance

from the discharge point, due to dilution and settling of the suspended material.

(1) It has been demonstrated that elevated suspended solids concentrations are generally confined to the immediate vicinity of the dredge or discharge point and dissipate rapidly at the completion of the operation. If turbidity is used as a basis for evaluating the environmental impact of a dredging or disposal operation, it is essential that the predicted turbidity levels are evaluated in light of background conditions. Average turbidity levels, as well as the occasional relatively high levels that are often associated with naturally occurring storms, high wave conditions, and floods, should be considered.

(2) Other activities of man may also be responsible for generating as much or more turbidity than dredging and disposal operations. For example, each year shrimp trawlers in Corpus Christi Bay, Texas, suspend 16 to 131 times the amount of sediment that is dredged annually from the main ship channel. In addition, suspended solids levels of 0.1 to 0.5 ppt generated behind the trawlers are comparable to those levels measured in the turbidity plumes around open-water pipeline disposal operations. Resuspension of bottom sediment in the wake of large ships, tugboats, and tows can also be considerable. In fact, where bottom clearance is 3 ft or less, there may be scour to a depth of 3 ft if the sediment is easily resuspended.

4-8. Environmental Impacts on the Benthos.

a. Physical. Whereas the impact associated with water-column turbidity around dredging and disposal operations is for the most part insignificant, the dispersal of fluid mud dredged material appears to have a relatively significant short-term impact on the benthic organisms within open-water disposal areas. Open-water pipeline disposal of fine-grained dredged material slurry may result in a substantial reduction in the average abundance of organisms and a decrease in the community diversity in the area covered by fluid mud. Despite this immediate impact, recovery of the community apparently begins soon after the disposal operation ceases.

(1) Disposal operations will blanket established bottom communities at the site with dredged material which may or may not resemble bottom sediments at the disposal site. Recolonization of animals on the new substrate and the vertical migration of benthic organisms in newly deposited sediments can be important recovery mechanisms. The first organisms to recolonize dredged material usually are not the same as those which had originally occupied the site; they consist of opportunistic species whose environmental requirements are flexible enough to allow them to occupy the disturbed areas. Trends toward reestablishment of the original community are often noted within several months of disturbance, and complete recovery approached within a year or two. The general recolonization pattern is often dependent upon the nature of the adjacent undisturbed community, which provides a pool of replacement organisms capable of recolonizing the site by adult migration or larval recruitment.

(2) Organisms have various capabilities for moving upward through newly deposited sediments, such as dredged material, to reoccupy positions relative to the sediment-water interface similar to those maintained prior to burial by the disposal activity. Vertical migration ability is greatest in dredged material similar to that in which the animals normally occur and is minimal in sediments of dissimilar particle-size distribution. Bottom-dwelling organisms having morphological and physiological adaptations for crawling through sediments are able to migrate vertically through several inches of overlying sediment. However, physiological status and environmental variables are of great importance to vertical migration ability. Organisms of similar life-style and morphology react similarly when covered with an overburden. For example, most surface-dwelling forms are generally killed if trapped under dredged material overburdens, while subsurface dwellers migrate to varying degrees. Laboratory studies suggest vertical migration may very well occur at disposal sites, although field evidence is not available. Literature review (WES TR DS-78-1) indicates the vertical migration phenomenon is highly variable among species.

(3) Dredging and disposal operations have immediate localized effects on the bottom life. The recovery of the affected sites occurs over periods of weeks, months, or years, depending on the type of environment and the biology of the animals and plants affected. The more naturally variable the physical environment, especially in relation to shifting substrate due to waves or currents, the less effect dredging and disposal will have. Animals and plants common to such areas of unstable sediments are adapted to physically stressful conditions and have life cycles which allow them to withstand the stresses imposed by dredging and disposal. Exotic sediments (those in or on which the species in question does not normally live) are likely to have more severe effects when organisms are buried than sediments similar to those of the disposal site. Generally, physical impacts are minimized when sand is placed on a sandy bottom and are maximized when mud is deposited over a sand bottom. When disposed sediments are dissimilar to bottom sediments at the sites, recolonization of the dredged material will probably be slow and carried out by organisms whose life habits are adapted to the new sediment. The new community may be different from that originally occurring at the site.

(4) Dredged material discharged at disposal sites which have a naturally unstable or shifting substrate due to wave or current action is rather quickly dispersed and does not cover the area to substantial depths. This natural dispersion, which usually occurs most rapidly and effectively during the stormy winter season, can be assisted by conducting the disposal operation so as to maximize the spread of dredged material, producing the thinnest possible overburden. The thinner the layer of overburden, the easier it is for mobile organisms to survive burial by vertical migration through dredged material. The desirability of minimizing physical impacts by dispersion can be overridden by other considerations, however. For example, dredged material shown by biological or chemical testing to have a potential for adverse environmental impacts might best be placed in an area of retention, rather than dispersion. This would maximize habitat disruption in a restricted area, but would confine potentially more important chemical impacts to the same small area.